

**BEDU**  
≡ POMPEN ≡

**D, T, & P SERIES**



Magnetically Coupled  
Precision Pumps

Pump Your Heart Into It

**BEDU**  
≡ POMPEN ≡

 **Tuthill**

## »» PERFECT FOR TECHNICALLY PRECISE & DEMANDING APPLICATIONS

Since 1977, Tuthill has worked to improve magnetically driven gear pumps by engineering solutions to meet the needs of varying applications and exacting designer specifications. The result is a family of magnetically coupled pumps that have found wide industry acceptance for their versatility and robust standard of build and reliability.

These pumps are known for their magnetically coupled, leak-free, seal-less construction and the non-pulsing flow of their external gear design. This makes them perfect for demanding applications such as medical equipment, laboratory equipment, chemical metering, laser cooling, and industrial temperature control. If it requires a seal free, technically advanced pump, Tuthill Magnetically Coupled Pumps are the solution.

### PERFORMANCE RANGE

- Flow Range 0.015 to 650 GPH (0.06 to 2460 LPH)
- Differential Pressure to 250 PSI (17.2 BAR)
- System Pressure to 500 PSI (34.5 BAR)
- Viscosity 0.3 cps to 2,000 cps
- Temperature -50 °F to 350 °F (-46 °C to 176 °C)

### FEATURES

- Valveless Design, No Vapor Trapping
- Exceptional Turndown Ratio 100:1
- Field Repairable - Easy and Quick
- Self Priming
- Low Shear
- Robust 5 bearing design
- Efficient Modular Design

## »» MAGNETICALLY COUPLED EXTERNAL GEAR PUMPS

The external gear design offers flow that is relatively independent of pressure providing constant fluid delivery with no pulsations. The flow will have a controlled volume that is accurate and repeatable, making it highly suitable for metering applications. The D, T, & P Series pumps can meet these demands in circumstances with high differential pressures and high system pressures, as well as thin to moderate viscosity fluids. The high volumetric efficiency is achieved by utilizing two identical gears that rotate against each other.

- One gear is driven by being coupled with the magnet. The other gear, the driven gear, rotates in the opposite direction. The un-meshing of the gears creates a vacuum on the inlet side, pulling media into the pump
- The media flows around the gears and housing to the discharge side
- The gears mesh back together forcing the media out the discharge end precisely into your application

The magnetically coupled construction requires no packing or mechanical seals. This also means there are no diaphragms or plastic tubes to rupture, making them leak free.

Quality 316 Stainless Steel, Hastelloy, Titanium, or Engineered Plastic construction with engineered plastic gears and bearings provides excellent resistance to chemicals and corrosive fluids.

### BENEFITS

- Long Life - Up to 20,000 Hours
- Metering Accuracy Better Than 1%
- Continuous Fixed Displacement Flow
- Virtually No Pulsation
- Easy, Low Cost Installation and Start Up

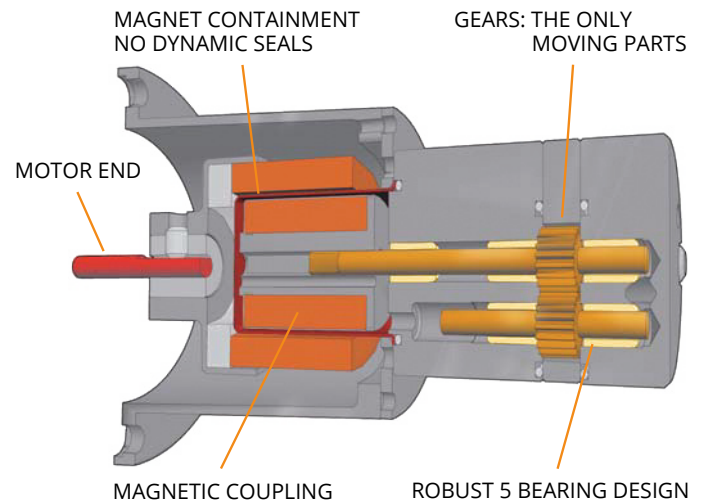

## »» PUMPS MAGNETICALLY COUPLED TO A RANGE OF STANDARD MOTORS

The pumps are designed to operate at 2-pole and 4-pole motor speeds, eliminating the need for gear reducers. The flow can be easily and precisely controlled by using standard AC, DC, BLDC, and Air motors and controllers.

AC motors are available in local voltage frequency combinations, either single or three phase. The pumps can be adapted to IEC and NEMA motors, including Explosion Proof designs. Variable Speed Drives are available.

## »» CHEMICAL RESISTANT METALS

A vast knowledge of magnet, pump, and motor technology is utilized in the design, manufacturing, and application of our magnetically coupled pumps.

The long life and non-pulsing flow of the external gear design are combined with the magnetically coupled, leak-free, seal less construction. Temperatures to 350°F (176°C) and viscosities from 0.3 cps to over 10,000 cps make this pump tough and reliable.

### D SERIES



- Flow Range .015 to 121 GPH (.06 to 458 LPH)
- Differential Pressures to 250 PSI (17.2 BAR)
- System Pressure to 500 PSI (34.5 BAR)
- Viscosities from 0.3 cps to 2,000 cps without speed reduction
- Temperature -50 °F to 350 °F (-46 °C to 176 °C)
- ATEX Approved

### T SERIES



- Flow Range 20 to 650 GPH (75 to 2460 LPH)
- Differential Pressures to 250 PSI (17.2 BAR)
- System Pressure to 500 PSI (34.5 BAR)
- Viscosities from 0.3 cps to 2,000 cps without speed reduction
- Temperatures -50 °F to 350 °F (-46 °C to 176 °C)
- ATEX Approved

## »» ENGINEERED PLASTIC ALTERNATIVES

The P Series magnetically coupled external gear pumps are constructed with Polyphenylene Sulfide (PPS), a highly durable engineered plastic.

The PPS pumps produce a consistent non-pulsing flow, providing a versatile and durable solution in many applications.

### P SERIES



- Flow Range 1 to 65 GPH (3.8 to 246 LPH)
- Differential Pressures to 130 PSI (9 BAR)
- System Pressure to 300 PSI (20.7 BAR)
- Viscosities from 0.3 cps to 1,000 cps without speed reduction
- Temperatures 0 °F to 150 °F (18 °C to 65 °C)

## » SPECIFICATION DATA

DISPLACEMENT ML/REV	PUMP SERIES	MAXIMUM SPEED RPM	MAXIMUM DIFFERENTIAL PRESSURE				FLOW @ 0 PRESSURE			
			INTERMITTENT		CONTINUOUS		MAXIMUM TEMPERATURE		3500 RPM	2900 RPM
			PSI	BAR	PSI	BAR	°F	°C	GPH	LPH
.11	D	5000	250	17.2	250	17.2	350	177	6	18
.19	D	5000	250	17.2	250	17.2	350	177	10	31
.23	D	5000	250	17.2	250	17.2	350	177	12	38
.38	D	5000	250	17.2	250	17.2	350	177	20	63
.57	D	5000	250	17.2	250	17.2	350	177	30	94
.68	D	5000	250	17.2	200	13.8	350	177	35	112
.80	D	5000	250	17.2	200	13.8	350	177	42	132
.99	D	5000	200	13.8	140	9.7	350	177	52	164
1.2	D	5000	200	13.8	140	9.7	350	177	63	198
1.3	D	5000	175	12.1	125	8.6	350	177	68	215
1.6	D	5000	150	10.3	100	6.9	350	177	84	264
2.0	D	5000	150	10.3	100	6.9	350	177	105	331
2.3	D	5000	150	10.3	100	6.9	350	177	121	380
2.6	T	5000	250	17.2	150	10.3	350	177	137	430
5.3	T	5000	145	10	100	6.9	350	177	279	876
7.9	T	4000	95	6.6	70	4.8	350	177	416	1306
8.0	T	4000	150	10.3	125	8.6	350	177	421	1343
12.	T	4000	120	8.2	100	6.9	350	177	650	2015
.38	P	4000	130	9.0	130	9.0	150	66	20	63
.57	P	4000	110	7.6	110	7.6	150	66	30	94
.68	P	4000	90	6.2	90	6.2	150	66	36	112
1.2	P	4000	70	4.8	70	4.8	150	66	63	198

## » MATERIALS OF CONSTRUCTION

	D SERIES	T SERIES	P SERIES
<b>Wetted Components</b>	316 SS, Hastelloy, or Titanium	316 SS, Hastelloy, or Titanium	PPS with 316 SS, Hastelloy, or Titanium Trim
<b>Gears</b>	PPS, PEEK, or LCP	PPS or PEEK	PPS
<b>Bearings</b>	PPS, PEEK, or LCP	PPS or PEEK	PPS
<b>O-Rings</b>	Viton, PTFE, EPR, Nitrile, or Neoprene	Viton, PTFE, EPR, Nitrile, or Neoprene	Viton, EPR, Nitrile, or Neoprene
<b>Magnets</b>	Encapsulated Ceramic or Samarium Cobalt	Encapsulated Samarium Cobalt	Encapsulated Ceramic or Samarium Cobalt

316 SS = Stainless Steel  
 PPS = Polyphenylene Sulfide  
 PEEK = PolyEtherEtherKetone

EPR = Ethylene Propylene Rubber  
 LCP = Liquid Crystal Polymer



Tuthill's magnetically coupled external gear pumps offer precision and reliability to laboratory and medical equipment manufacturers.

## »» INDUSTRIES AND APPLICATIONS

### WATER & WASTE WATER TREATMENT CHEMICAL METERING

- ALUMS
- AQUEOUS AMMONIA
- BIOXIDE
- BOILER FEED
- CAUSTIC SODA
- COOLING TOWER
- CALCIUM HYDROXIDE
- CALCIUM HYPOCHLORITE
- COPPER SULFATE
- FERRIC CHLORIDE
- FERRIC SULFATE
- HYDROFLUOROSILICIC ACID
- HYDROGEN PEROXIDE
- METHANOL
- OIL/WATER SUSPENSION
- PERMANGANATE
- POLYMERS
- POTASSIUM PERMANGANATE
- POLYALUMINUM CHLORIDE
- SODIUM HYPOCHLORITE
- SODIUM BISULFITE
- SODIUM ALUMINATE
- SODIUM CARBONATE (SODA ASH)
- SODIUM HYDROSULFITE
- SODIUM HYDROXIDE
- SODIUM SILICATE
- SULFURIC ACID

### MEDICAL EQUIPMENT

- CT & X-RAY OIL BATH CIRCULATION
- DIALISATE FOR CLEANING (KIDNEY DIALYSIS)
- LASER COOLING
- LIQUID CHROMATOGRAPHY SOLVENTS
- SLIDE STAINING
- TEMPERATURE CONTROL

### OIL & GAS

- DIESEL
- FUEL DISPENSING SOLVENTS
- GASOLINE
- KAROSENE
- OIL RECYCLING

### CHEMICAL

- ADHESIVE DISPENSING

### SEMICONDUCTOR EQUIPMENT

- HEAT TRANSFER FLUID (FLOURINERT)

### PERSONAL PRODUCTS

- ACTIVE INGREDIENTS
- COLORANTS
- DETERGENTS
- DYES
- NEUTRALIZING CHEMICALS
- PERFUMES & FRAGRANCES
- SOAPS

### PAINTS, COATINGS, & PRINTING INKS

- ADDITIVES
- DYES & COLORANTS
- INK TO PRINT HEAD
- MEK BASED INK

### TRANSPORTATION

- AIRPORT DETECTION SYSTEMS
- CLEANING AGENTS
- DIESEL FUEL
- ENGINE TESTING
- FUEL INJECTION CLEANING
- OIL BATH CIRCULATION
- PEM FUEL CELL COOLING
- TRANSMISSION FLUID (ATF)
- UNLEADED

### BIODIESEL

- FINISHED PRODUCTS
  - FUELS
  - GLYCERIN
- RAW MATERIAL
  - FATS AND OIL

### FOOD AND BEVERAGE

- ACIDS & CAUSTICS
- BAKERY RELEASE OIL SPRAY
- COLORANTS
- ETHYLENE GLYCOL STERILIZATION
- FLAVORING

### AGRICULTURE

- ANIMAL FEED SYSTEMS
- ANTI-FUNGAL SPRAY
- BACTERIAL SPRAY
- INSECTICIDE FOGGER

### PULP & PAPER ADDITIVES

- BLEACHING
- COOKING
- SCREENING
- PAPER MACHINE
- WASHING

BEDU POMPEN B.V.

Poort van Midden Gelderland Rood 10

6666 LT HETEREN

Nederland

Telefoon +31 (0)88 4802 900

Fax +31 (0)88 4802 901

E-mail [info@bedu.nl](mailto:info@bedu.nl)

[WWW.BEDU.NL](http://WWW.BEDU.NL)

BEDU BELGIUM B.V.B.A.

Industriepark-West 75

9100 SINT-NIKLAAS

België

Telefoon +32 (0)3 80 87 980

Fax +32 (0)3 80 87 981

E-mail [info@bedu.be](mailto:info@bedu.be)

[WWW.BEDU.BE](http://WWW.BEDU.BE)

**BEDU**  
≡ P O M P E N ≡



### ***THE HEART IS THE ORIGINAL PUMP***

All of us are born with a pump inside – our hearts. At Tuthill, we don't just make pumps, blowers, and vacuum systems & blowers, we make an invitation for the original pump – the heart – to come alive.

We've always been a company with heart. From our beginnings as a brick maker, we made the bricks that made Chicago. As the horses hauled clay from the quarry, it was too much for their hearts to bear. So Tuthill created an oil pump to power a truck, an innovation that saved horses and led to our first manufactured pump – made from the heart.

Today, we pump our hearts into everything we do: every cut, drill, and cycle, and everything we bring to you. We invite you to join us and find what makes your heart beat a little faster. Because when we all come alive, the world comes along.

