

**BEDU**  
≡ POMPEN ≡

# ECO SNL IN-LINE CENTRIFUGAL PUMPS



**made for your process**



# ECO SNL IN-LINE PUMPS



## Handled Liquids

Clean or slightly contaminated low viscosity liquids without solid & fibrous particles.

## Technical Data

Discharge Flange \_\_\_\_\_ DN 40.....DN 150 mm

Capacity \_\_\_\_\_ up to 350 m<sup>3</sup>/h(\*)

Head \_\_\_\_\_ up to 100 m(\*)

Speed \_\_\_\_\_ up to 3000 rpm

Design Temperature \_\_\_\_\_ -10 °C' to +140 °C(\*\*)

Casing Pressure (Pmax) \_\_\_\_\_ 10 bar (16 bar)(\*\*)

(Pmax: Suction Pressure + Shut off Head)

(\*) Contact company for higher capacity and head values.

(\*\*) The Material of pump differs according to the type of pumped liquid, operating temperature and pressure. Contact for detailed information.

## Design Features

•In-line, rigidly-coupled, volute casing, single stage centrifugal pump with closed impeller.

•Complies EU547/2012 regulations.

•Suction and discharge flanges conform to EN 1092-2 / PN 16. The flanges are according to EN 1092-1 / PN 16 for steel or stainless steel casing. In case of request, ANSI/ASME flanges can be supplied.

## Pump Designation

Pump Type \_\_\_\_\_

Suction and Discharge Nozzle (DN-mm) \_\_\_\_\_

Nominal Impeller Diameter (mm) \_\_\_\_\_

Special Application \_\_\_\_\_

•Pumps are rigidly coupled with electric motors of IEC frame sizes with high efficiency class.

•All impellers are balanced dynamically or statically according to ISO 1940 grade 6.3.

•Axial thrust is balanced by impeller balancing holes system.

•Direction of rotation is clockwise viewed from drive end.

•In case of request, wear ring and/or shaft sleeve can be supplied.

•The pump and motor have separate shafts connected by a rigid coupling or through slide fit shaft. Axial and radial forces are absorbed by electric motor bearings.

## Shaft Sealing

•Depending on customer request or liquid type, mechanical seals are available.

# ECO SNL 100 - 250 - XXX

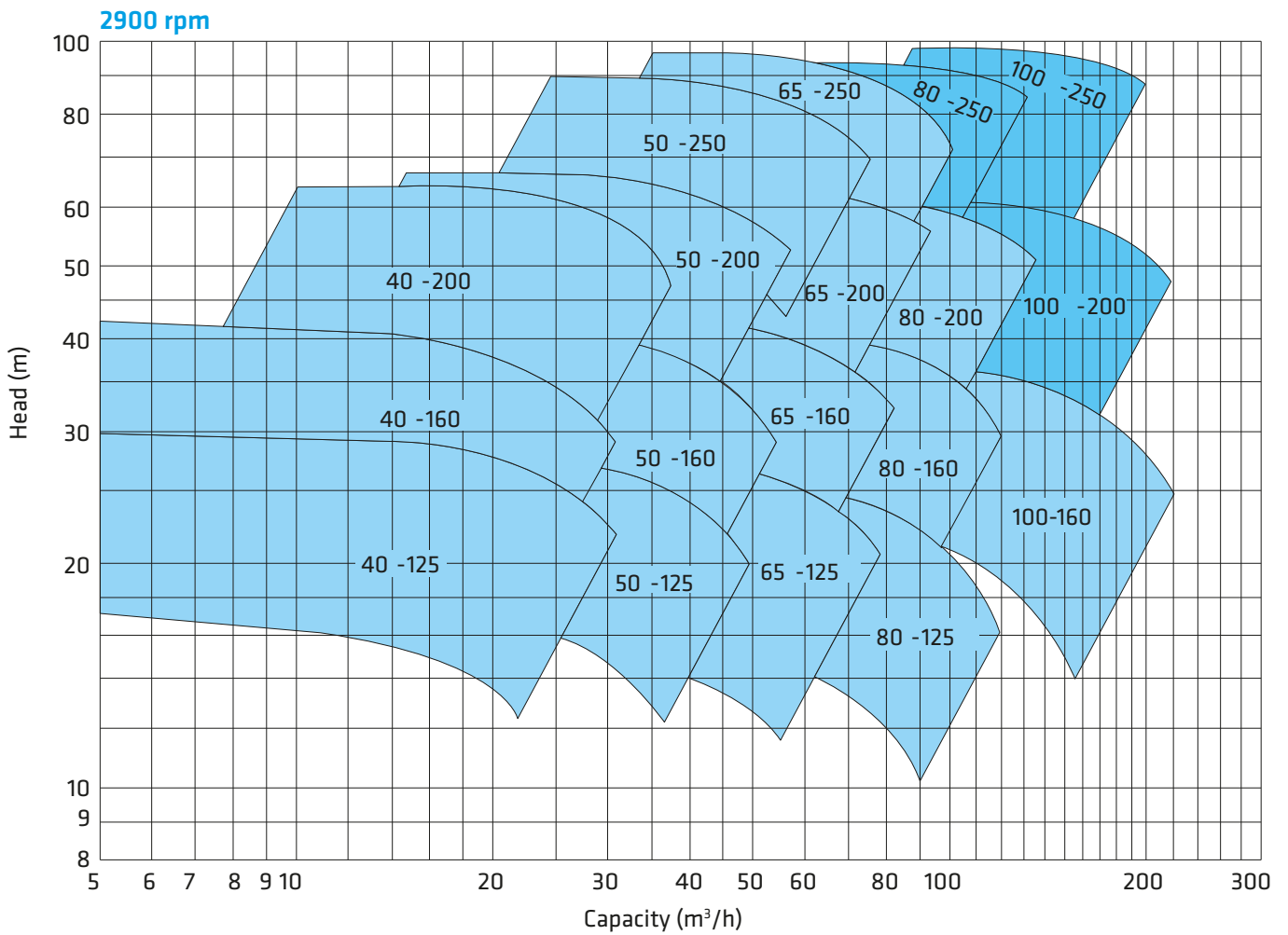
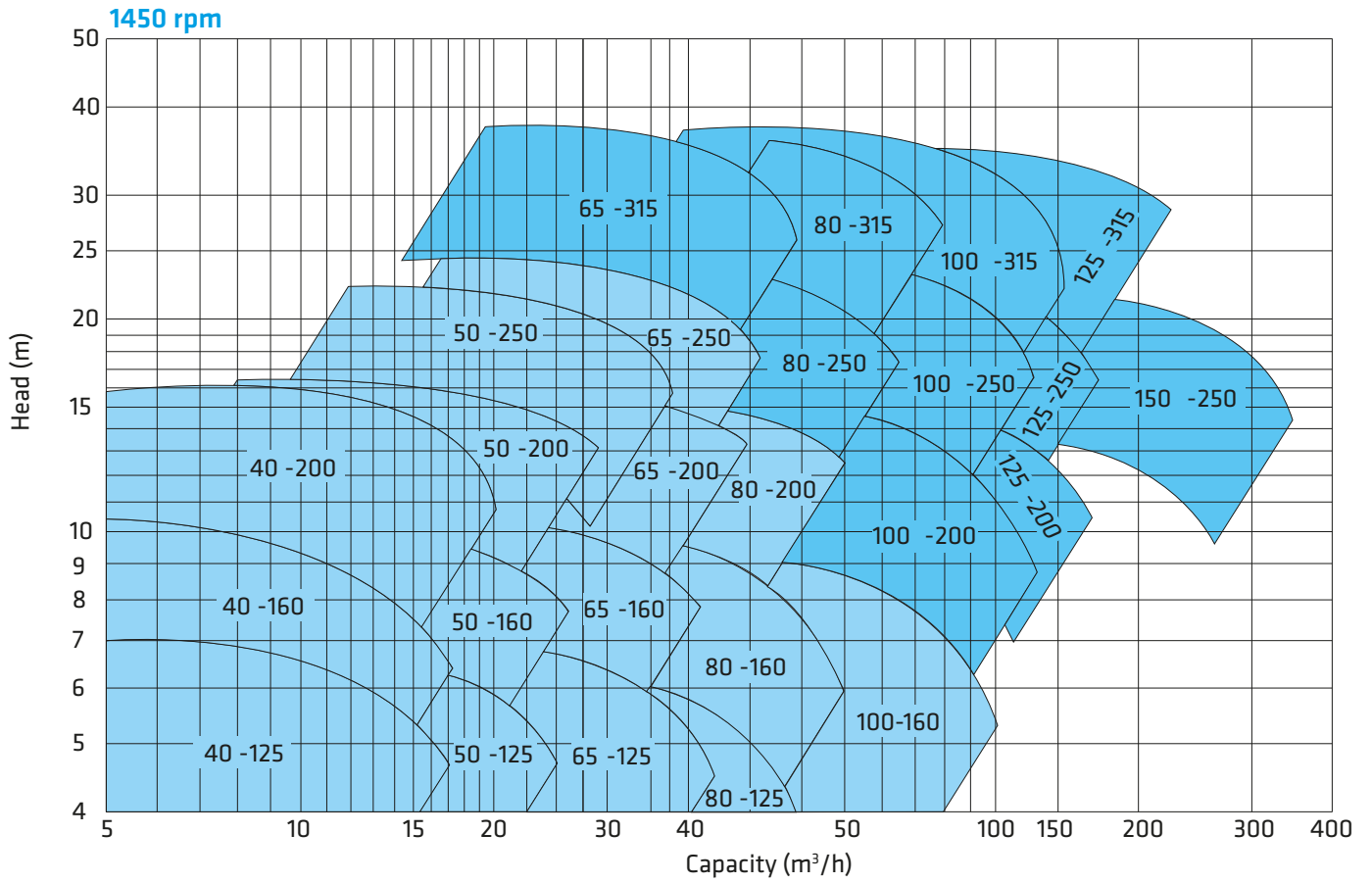

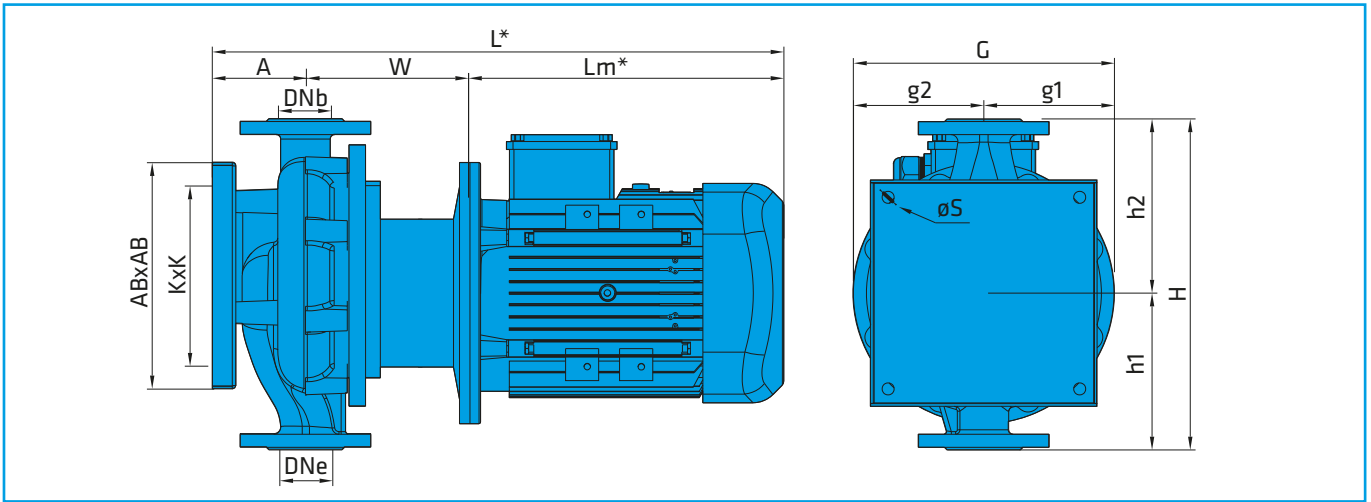

2900 rpm ( 2 Pole Motor)

FORM	Pump Type	MOTOR		DNe DNb mm	ECO SNL INSTALLATION DIMENSIONS (mm)													Base Plate (**)
		kW	IEC		A	W	Lm*	L*	H	h1	h2	G	g1	g2	ABxAB	KxK	øS	
F1	40-125	1,5	90L	40	109	156	267	532	300	140	160	210	110	100	170	130	14	T0
F1	40-125	2,2	90L	40	109	156	267	532	300	140	160	210	110	100	170	130	14	T0
F1	40-125	3	100L	40	109	179	292	580	300	140	160	210	110	100	170	130	14	T1
F1	40-125	4	112M	40	109	179	336	624	300	140	160	210	110	100	170	130	14	T1
F1	40-160	2,2	90L	40	103	156	267	526	340	160	180	245	130	115	170	130	14	T0
F1	40-160	3	100L	40	103	179	292	574	340	160	180	245	130	115	200	160	14	T1
F1	40-160	4	112M	40	103	179	336	618	340	160	180	245	130	115	200	160	14	T1
F1	40-160	5,5	132S	40	103	189	361	652	340	160	180	245	130	115	200	160	14	T1
F2	40-200	5,5	132S	40	107	189	360	657	380	180	200	275	140	135	260	220	14	T2
F2	40-200	7,5	132M	40	107	189	396	692	380	180	200	275	140	135	260	220	14	T2
F2	40-200	11	160M	40	107	226	466	799	380	180	200	275	140	135	260	220	14	T2
F1	50-125	2,2	90L	50	133	156	267	556	360	160	200	220	120	100	200	160	14	T1
F1	50-125	3	100L	50	133	179	292	604	360	160	200	220	120	100	200	160	14	T1
F1	50-125	4	112M	50	133	179	335	647	360	160	200	220	120	100	200	160	14	T1
F1	50-125	5,5	132S	50	133	189	361	683	360	160	200	220	120	100	200	160	14	T1
F1	50-160	4	112M	50	138	179	336	653	340	160	180	255	135	120	200	160	14	T1
F1	50-160	5,5	132S	50	138	189	361	687	340	160	180	255	135	120	200	160	14	T1
F1	50-160	7,5	132M	50	138	189	396	723	340	160	180	255	135	120	200	160	14	T1
F2	50-200	7,5	132M	50	122	189	396	707	425	200	225	280	145	135	260	220	14	T2
F2	50-200	11	160M	50	122	226	466	814	425	200	225	280	145	135	260	220	14	T2
F2	50-200	15	160M	50	122	226	466	814	425	200	225	280	145	135	260	220	14	T2
F2	50-200	18,5	160M	50	122	226	466	814	425	200	225	280	145	135	260	220	14	T2
F2	50-250	15	160L	50	117	226	466	809	475	225	250	340	175	165	260	220	14	T2
F2	50-250	18,5	160L	50	117	226	466	809	475	225	250	340	175	165	260	220	14	T2
F2	50-250	22	180M	50	117	226	519	862	475	225	250	340	175	165	260	220	14	T2
F2	50-250	30	200L	50	124	226	555	905	475	225	250	340	175	165	320	270	18	T3
F1	65-125	3	100L	65	163	179	292	634	340	160	180	250	140	110	200	160	14	T1
F1	65-125	4	112M	65	163	179	336	678	340	160	180	250	140	110	200	160	14	T1
F1	65-125	5,5	132S	65	163	189	360	712	340	160	180	250	140	110	200	160	14	T1
F1	65-125	7,5	132M	65	163	189	396	748	340	160	180	250	140	110	200	160	14	T1
F1	65-160	5,5	132S	65	147	189	360	696	380	180	200	280	150	130	260	220	14	T2
F1	65-160	7,5	132M	65	147	189	396	732	380	180	200	280	150	130	260	220	14	T2
F1	65-160	11	160M	65	147	226	466	839	380	180	200	280	150	130	260	220	14	T2
F1	65-160	15	160M	65	147	226	466	839	380	180	200	280	150	130	260	220	14	T2
F2	65-200	11	160M	65	132	226	466	824	475	225	250	300	155	145	260	220	14	T2
F2	65-200	15	160M	65	132	226	466	824	475	225	250	300	155	145	260	220	14	T2
F2	65-200	18,5	160M	65	132	226	466	824	475	225	250	300	155	145	260	220	14	T2
F2	65-200	22	180M	65	132	226	519	877	475	225	250	300	155	145	260	220	14	T2
F2	65-250	18,5	160L	65	132	226	466	824	475	225	250	345	180	165	260	220	14	T2
F2	65-250	22	180M	65	132	226	519	877	475	225	250	345	180	165	260	220	14	T2
F2	65-250	30	200L	65	132	226	555	920	475	225	250	345	180	165	320	270	18	T3
F2	65-250	37	200L	65	132	226	555	920	475	225	250	345	180	165	320	270	18	T3
F1	80-160	7,5	132M	80	162	189	396	747	425	200	225	295	160	135	260	220	14	T2
F1	80-160	11	160M	80	162	226	466	854	425	200	225	295	160	135	260	220	14	T2
F1	80-160	15	160M	80	162	226	466	854	425	200	225	295	160	135	260	220	14	T2
F2	80-200	15	160M	80	152	226	466	844	475	225	250	315	170	145	260	220	14	T2
F2	80-200	18,5	160M	80	152	226	466	844	475	225	250	315	170	145	260	220	14	T2
F2	80-200	22	180M	80	152	226	519	897	475	225	250	315	170	145	260	220	14	T2
F2	80-200	30	200L	80	159	226	555	940	475	225	250	315	170	145	320	270	18	T3

## 2900 rpm ( 2 Pole Motor)

FORM	Pump Type	MOTOR		DNe DNb mm	ECO SNL INSTALLATION DIMENSIONS (mm)													Base Plate (**)
		kW	IEC		A	W	Lm*	L*	H	h1	h2	G	g1	g2	ABxAB	KxK	øS	
F2	80-250	30	200L	80	184	246	555	985	560	280	280	375	195	180	320	270	18	T3
F2	80-250	37	200L	80	184	246	555	985	560	280	280	375	195	180	320	270	18	T3
F2	80-250	45	225M	80	184	248	625	1057	560	280	280	375	195	180	320	270	18	T3
F2	80-250	55	250M	80	189	294	753	1236	560	280	280	375	195	180	400	350	18	T4
F1	100-160	11	160M	100	224	226	466	916	475	175	300	370	200	170	320	270	18	T3
F1	100-160	15	160M	100	224	226	466	916	475	175	300	370	200	170	320	270	18	T3
F1	100-160	18,5	160M	100	224	226	466	916	475	175	300	370	200	170	320	270	18	T3
F1	100-160	22	180M	100	224	226	519	969	475	175	300	370	200	170	320	270	18	T3
F1	100-160	30	200L	100	224	226	555	1005	475	175	300	370	200	170	320	270	18	T3
F1	100-200	22	180M	100	202	244	519	965	550	250	300	350	190	160	260	220	14	T2
F1	100-200	30	200L	100	209	246	555	1010	550	250	300	350	190	160	320	270	18	T3
F1	100-200	37	200L	100	209	246	555	1010	550	250	300	350	190	160	320	270	18	T3
F1	100-200	45	225M	100	209	248	625	1082	550	250	300	350	190	160	320	270	18	T3
F2	100-250	37	200L	100	204	246	555	1005	580	280	300	380	205	175	320	270	18	T3
F2	100-250	45	225M	100	204	248	625	1077	580	280	300	380	205	175	320	270	18	T3
F2	100-250	55	250M	100	209	294	754	1257	580	280	300	380	205	175	400	350	18	T4
F2	100-250	75	280M	100	209	294	886	1389	580	280	300	380	205	175	400	350	18	T4
F2	100-250	90	280M	100	209	294	886	1389	580	280	300	380	205	175	400	350	18	T4

## 1450 rpm ( 4 Pole Motor)

FORM	Pump Type	MOTOR		DNe DNb mm	ECO SNL INSTALLATION DIMENSIONS (mm)													Base Plate (**)
		kW	IEC		A	W	Lm*	L*	H	h1	h2	G	g1	g2	ABxAB	KxK	øS	
F1	40-125	0,37	71M	40	109	136	222	467	300	140	160	210	110	100	170	130	14	T0
F1	40-125	0,55	80M	40	109	156	243	509	300	140	160	210	110	100	170	130	14	T0
F1	40-160	0,37	71M	40	103	136	222	462	340	160	180	245	130	115	170	130	14	T0
F1	40-160	0,55	80M	40	103	156	243	503	340	160	180	245	130	115	170	130	14	T0
F1	40-160	0,75	80M	40	103	156	243	503	340	160	180	245	130	115	170	130	14	T0
F2	40-200	0,55	80M	40	103	156	244	503	380	180	200	275	140	135	200	160	14	T1
F2	40-200	0,75	80M	40	103	156	244	503	380	180	200	275	140	135	200	160	14	T1
F2	40-200	1,1	90L	40	103	156	267	526	380	180	200	275	140	135	200	160	14	T1
F2	40-200	1,5	90L	40	103	156	267	526	380	180	200	275	140	135	200	160	14	T1
F1	50-125	0,37	71M	50	133	136	222	492	360	160	200	220	120	100	200	160	14	T1
F1	50-125	0,55	80M	50	133	156	243	533	360	160	200	220	120	100	200	160	14	T1
F1	50-125	0,75	80M	50	133	156	243	533	360	160	200	220	120	100	200	160	14	T1
F1	50-160	0,55	80M	50	138	156	244	538	340	160	180	255	135	120	170	130	14	T1
F1	50-160	0,75	80M	50	138	156	244	538	340	160	180	255	135	120	170	130	14	T0
F1	50-160	1,1	90L	50	138	156	267	561	340	160	180	255	135	120	170	130	14	T0
F2	50-200	1,1	90L	50	118	156	267	541	425	200	225	280	145	135	200	160	14	T0
F2	50-200	1,5	90L	50	118	156	267	541	425	200	225	280	145	135	200	160	14	T1
F2	50-200	2,2	100L	50	118	179	292	589	425	200	225	280	145	135	200	160	14	T1
F2	50-250	2,2	100L	50	117	179	292	588	475	225	250	340	175	165	260	220	14	T1
F2	50-250	3	100L	50	117	179	292	588	475	225	250	340	175	165	260	220	14	T2
F2	50-250	4	112M	50	117	179	336	632	475	225	250	340	175	165	260	220	14	T2
F1	65-125	0,37	71M	65	163	136	222	522	340	160	180	140	110	140	200	160	14	T2
F1	65-125	0,55	80M	65	163	156	244	563	340	160	180	140	110	140	200	160	14	T1
F1	65-125	0,75	80M	65	163	156	244	563	340	160	180	140	110	140	200	160	14	T1
F1	65-125	1,1	90L	65	163	156	266	585	340	160	180	140	110	140	200	160	14	T1
F1	65-160	0,75	80M	65	143	156	244	543	380	180	200	150	130	150	200	160	14	T1
F1	65-160	1,1	90L	65	143	156	267	566	380	180	200	150	130	150	200	160	14	T1
F1	65-160	1,5	90L	65	143	156	267	566	380	180	200	150	130	150	200	160	14	T1
F1	65-160	2,2	100L	65	143	179	292	614	380	180	200	150	130	150	200	160	14	T1
F2	65-200	1,1	90L	65	132	156	267	555	475	225	250	300	155	145	260	220	14	T2
F2	65-200	1,5	90L	65	132	156	267	555	475	225	250	300	155	145	260	220	14	T2
F2	65-200	2,2	100L	65	132	179	292	603	475	225	250	300	155	145	260	220	14	T2
F2	65-200	3	100L	65	132	179	292	603	475	225	250	300	155	145	260	220	14	T2
F2	65-250	2,2	100L	65	132	179	292	603	475	225	250	345	180	165	260	220	14	T2
F2	65-250	3	100L	65	132	179	292	603	475	225	250	345	180	165	260	220	14	T2
F2	65-250	4	112M	65	132	179	336	647	475	225	250	345	180	165	260	220	14	T2
F2	65-250	5,5	132M	65	132	189	396	717	475	225	250	345	180	165	260	220	14	T2
F2	65-315	5,5	132M	65	169	215	396	780	560	280	280	420	220	200	400	350	18	T4
F2	65-315	7,5	132M	65	169	215	396	780	560	280	280	420	220	200	400	350	18	T4
F2	65-315	11	160M	65	169	245	466	880	560	280	280	420	220	200	400	350	18	T4
F1	80-160	1,1	90L	80	158	156	267	581	425	200	225	295	160	135	200	160	14	T1
F1	80-160	1,5	90L	80	158	156	267	581	425	200	225	295	160	135	200	160	14	T1
F1	80-160	2,2	100L	80	158	179	292	629	425	200	225	295	160	135	200	160	14	T1
F2	80-200	1,5	90L	80	152	156	267	575	475	225	250	315	170	145	260	220	14	T2
F2	80-200	2,2	100L	80	152	179	292	623	475	225	250	315	170	145	260	220	14	T2
F2	80-200	3	100L	80	152	179	292	623	475	225	250	315	170	145	260	220	14	T2
F2	80-200	4	112M	80	152	179	336	667	475	225	250	315	170	145	260	220	14	T2

## 1450 rpm ( 4 Pole Motor)

FORM	Pump Type	MOTOR		DNe DNb mm	ECO SNL INSTALLATION DIMENSIONS (mm)													Base Plate (**)
		kW	IEC		A	W	Lm*	L*	H	h1	h2	G	g1	g2	ABxAB	KxK	øS	
F2	80-250	3	100L	80	184	189	292	665	560	280	280	375	195	180	320	270	18	T3
F2	80-250	4	112M	80	184	189	336	709	560	280	280	375	195	180	320	270	18	T3
F2	80-250	5,5	132M	80	184	214	396	794	560	280	280	375	195	180	320	270	18	T3
F2	80-250	7,5	132M	80	184	214	396	794	560	280	280	375	195	180	320	270	18	T3
F2	80-315	5,5	132M	80	194	215	396	805	595	280	315	425	220	205	400	350	18	T4
F2	80-315	7,5	132M	80	194	215	396	805	595	280	315	425	220	205	400	350	18	T4
F2	80-315	11	160M	80	194	245	466	905	595	280	315	425	220	205	400	350	18	T4
F2	80-315	15	160M	80	194	245	466	905	595	280	315	425	220	205	400	350	18	T4
F1	100-160	1,5	90L	100	224	156	267	647	475	175	300	370	200	170	320	270	18	T3
F1	100-160	2,2	100L	100	224	179	292	695	475	175	300	370	200	170	320	270	18	T3
F1	100-160	3	100L	100	224	179	292	695	475	175	300	370	200	170	320	270	18	T3
F1	100-200	3	100L	100	202	189	292	683	550	250	300	350	190	160	260	220	14	T2
F1	100-200	4	112M	100	202	189	336	727	550	250	300	350	190	160	260	220	14	T2
F1	100-200	5,5	132M	100	202	214	396	812	550	250	300	350	190	160	260	220	14	T2
F2	100-250	4	112M	100	204	189	336	729	580	280	300	380	205	175	320	270	18	T3
F2	100-250	5,5	132M	100	204	214	396	814	580	280	300	380	205	175	320	270	18	T3
F2	100-250	7,5	132M	100	204	214	396	814	580	280	300	380	205	175	320	270	18	T3
F2	100-250	11	160M	100	204	244	466	914	580	280	300	380	205	175	320	270	18	T3
F2	100-315	7,5	132M	100	199	215	396	810	670	315	355	455	240	215	400	350	18	T4
F2	100-315	11	160M	100	199	245	466	910	670	315	355	455	240	215	400	350	18	T4
F2	100-315	15	160M	100	199	245	466	910	670	315	355	455	240	215	400	350	18	T4
F2	100-315	18,5	180M	100	199	245	519	963	670	315	355	455	240	215	400	350	18	T4
F1	125-200	4	112M	125	220	213	336	769	560	280	280	390	210	180	400	350	18	T4
F1	125-200	5,5	132M	125	220	238	396	854	560	280	280	390	210	180	400	350	18	T4
F1	125-200	7,5	132M	125	220	238	396	854	560	280	280	390	210	180	400	350	18	T4
F2	125-250	5,5	132M	125	220	239	396	854	630	315	315	410	215	195	400	350	18	T4
F2	125-250	7,5	132M	125	220	239	396	854	630	315	315	410	215	195	400	350	18	T4
F2	125-250	11	160M	125	220	269	466	954	630	315	315	410	215	195	400	350	18	T4
F2	125-250	15	160M	125	220	269	466	954	630	315	315	410	215	195	400	350	18	T4
F2	125-315	11	160M	125	200	240	396	835	710	355	355	490	260	230	400	350	18	T4
F2	125-315	15	160M	125	200	240	396	835	710	355	355	490	260	230	400	350	18	T4
F2	125-315	18,5	180M	125	200	270	519	988	710	355	355	490	260	230	400	350	18	T4
F2	125-315	22	180M	125	200	270	519	988	710	355	355	490	260	230	400	350	18	T4
F2	125-315	30	200L	125	200	272	555	1026	710	355	355	490	260	230	400	350	18	T4
F2	150-250	15	160L	150	220	290	466	974	710	355	355	470	250	220	400	350	18	T4
F2	150-250	18,5	180M	150	223	290	519	1032	710	355	355	470	250	220	400	350	18	T4
F2	150-250	22	180M	150	223	290	519	1032	710	355	355	470	250	220	400	350	18	T4

## Installation Arrangements

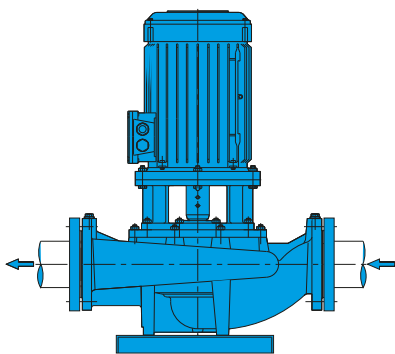

Standard installation type to horizontal pipe. (on ground)

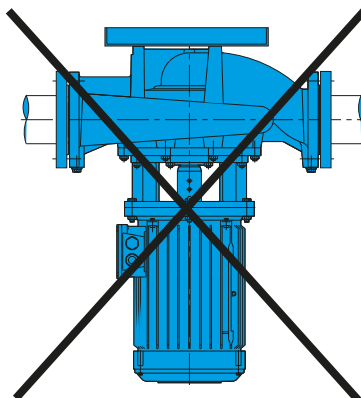

The axis of motor below the horizontal line is **not** admissible.

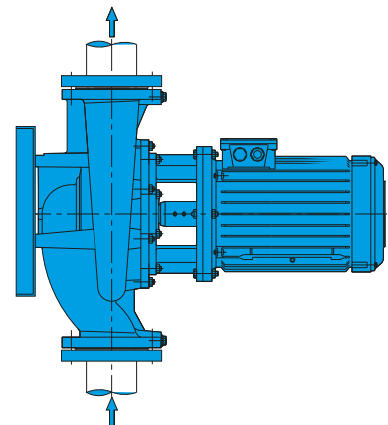

Please consult to Standart Pompa in case of installation to vertical pipes.

# Assembly Drawings

ECO SNL

Form: F1 (Slide - fit shaft application)

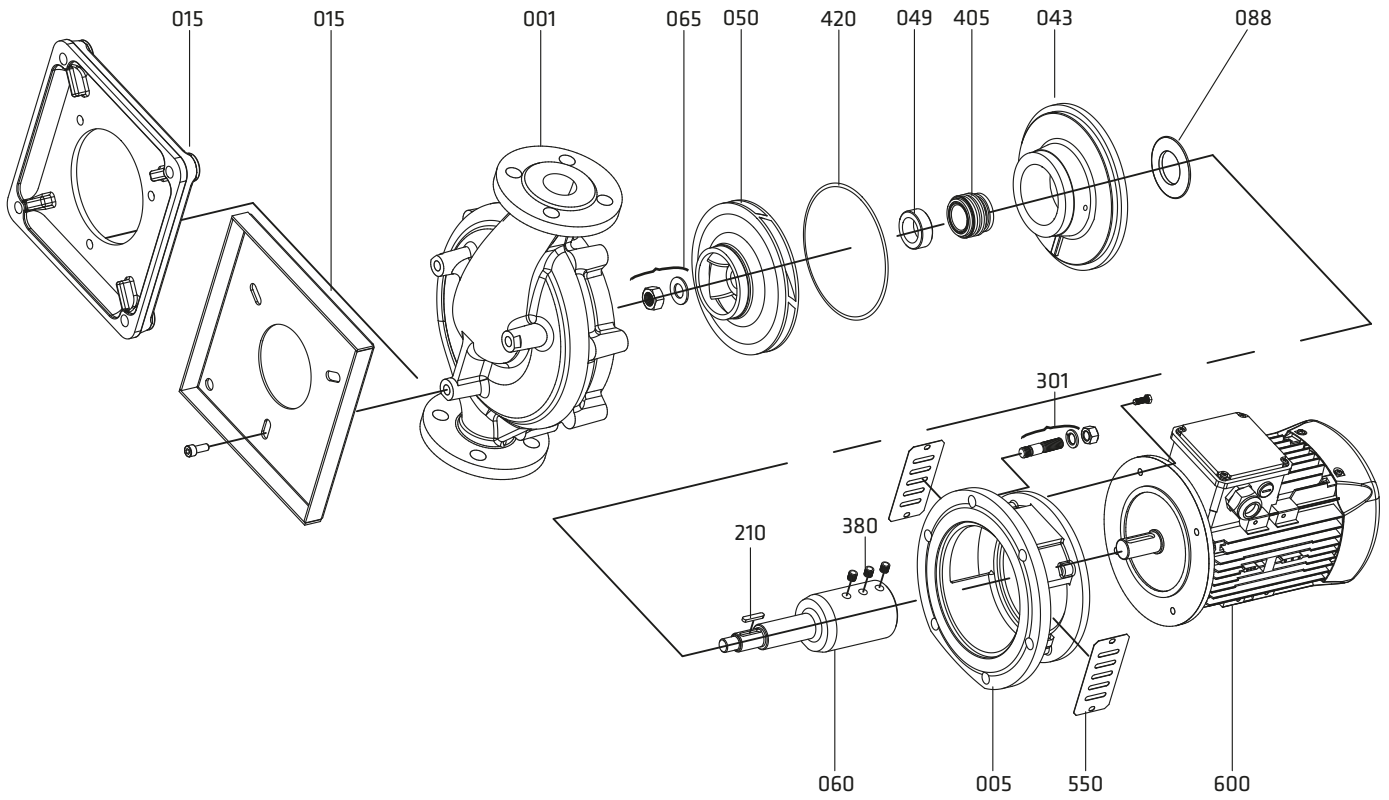

Form: F2 (Slide - fit shaft application)

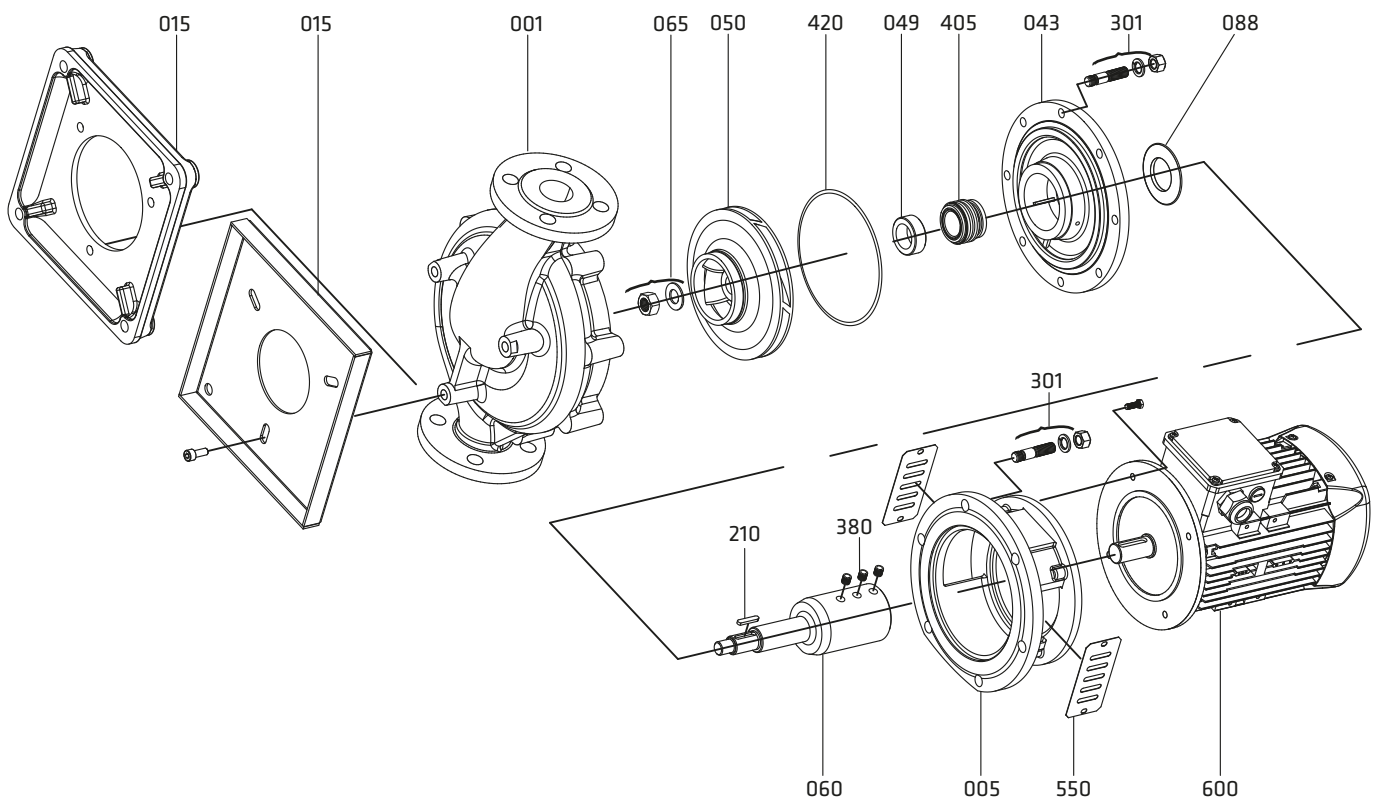

## Rigid Coupling Application

For motor shaft diameters of Ø60 mm or bigger.

# ECO SNL

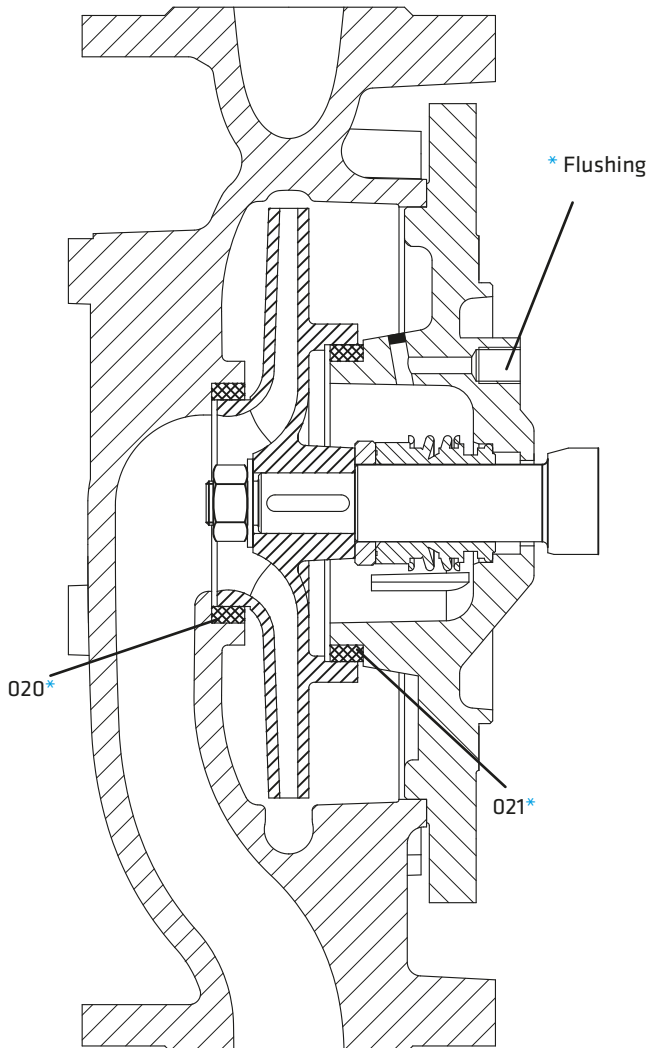
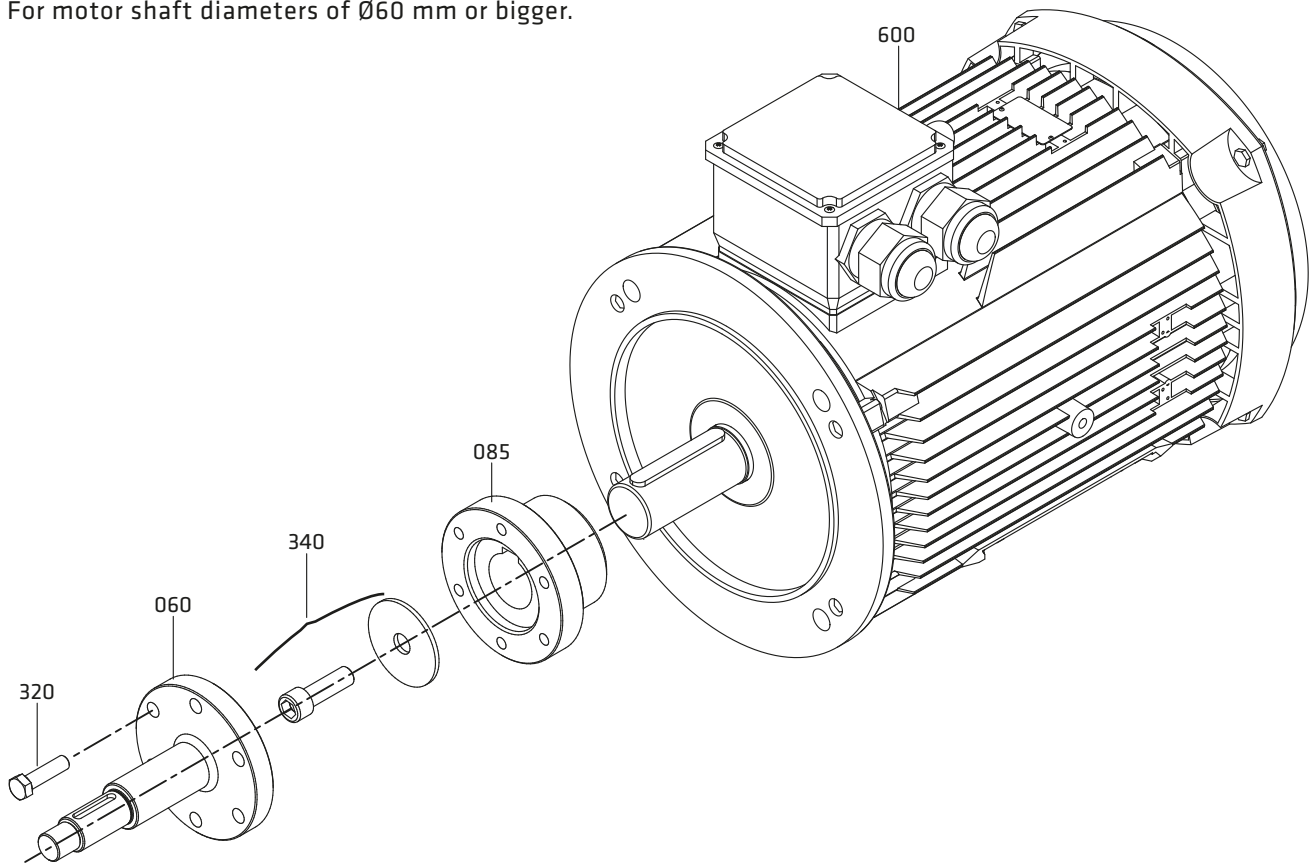

### Part List

001	Volute Casing
005	Motor Pedestal
015	Bottom Plate
020*	Wear Ring (casing)
021*	Wear Ring (seal cover)
043	Mechanical Seal Cover
049	Mechanical Seal Spacer Sleeve
050	Impeller
060	Shaft
065	Impeller Nut and Washer
088	Thrower
093	Rigid Coupling
210	Impeller Key
230	Screw
301	Stud, Washer and Nut
320	Screw
340	Alilen Screw and Washer
380	Set Screw
405	Mechanical Seal
420	O-ring
550	Guard
600	Electric Motor

(\*) Optional



PART LIST	10	30	35	20	60	6L	70	7L	8M	7D	7S	8N	80	4C	4A	40	80	8T	60	7L	7E	7D	
	0.6025	0.7040	0.7043	1.0619	1.4308	1.4309	1.4408	1.4409	1.4500	1.4517	1.4469	1.4317	1.4008	2.1050.01	2.0975.01	2.1096.01	1.4021	1.4021+QT	1.4301	1.4404	1.4460	1.4462	
Volute Casing	●	○	○	○	○	○	○	○	○	○	○	○	○	○	○	○							
Mechanical Seal Cover	●	○	○	○	○	○	○	○	○	○	○	○	○	○	○	○							
Impeller	●	○	○	○	○	○	○	○	○	○	○	○	○	○	○	○						○	
Shaft																	●	○	○	○			○
Motor Pedestal	●	○	○	○	○	○	○	○															
Wear Ring	○	○	○	○	○	○	○	○	○	○	○	○	○	○	○	○							
Mech Seal Spacer Sleeve																	●	○	○	○			○
Mechanical Seal (*)	EN 12756																						
Bottom Plate	According to pump types, steel or cast iron material can be used. Contact company for non-standard application.																						

(\*) Optional :Depending on customer requirement or request different types and brands of mechanical seals are applicable.

● Standard manufacturing  
○ Optional

NOTE: Depends on the request, different than above casting and shaft material can be supplied.

### Material Equivalents

Description	DIN / EN		AISI / SAE / ASTM
Cast Iron	0.6025	EN-GJL-250 (GG25)	A48 Class 40B
Nodular Cast Iron	0.7040	EN-GJS-400-15 (GGG40)	A536 60-40-18
Nodular Cast Iron	0.7043	EN-GJS-400-18-LT (GGG40.3)	A536 60-40-18
Cast Steel	1.0619	GP240GHGS-C25	A216 WCB
Chrome Nickel Cast Steel	1.4308	GX5CrNi19-10	A351 CF8
Chrome Nickel Cast Steel (low carbon)	1.4309	GX2CrNi19-11	A351 CF3
Chrome Nickel Molybdenum Cast Steel	1.4408	GX5CrNiMo19-11-2	A351 CF8M
Chrome Nickel Molybdenum Cast Steel (low carbon)	1.4409	GX2CrNiMo19-11-2	A351 CF3M
Austenitic Cast Steel	1.4500	GX7NiCrMoCuNb25-20	A351 CN7M
Austenitic - Ferritic Cast Steel (duplex)	1.4517	GX2CrNiMoCuN25-6-3-3	A890 CD4MCuN
Austenitic - Ferritic Cast Steel (super duplex)	1.4469	GX2CrNiMoN26-7-4	A890 CE3MN
Martenzitic Stainless Cast Steel	1.4317	GX4CrNi13-4	A352 CA6NM
Martenzitic Stainless Cast Steel	1.4008	GX7CrNiMo12-1	A217 CA15
Cast Bronze (tin alloy)	2.1050.01	G-CuSn10	B427 C90700
Cast Bronze (nickel alloy)	2.0975.01	G-CuAl10Ni	B148 C95500
Cast Bronze (Leaded)	2.1096.01	G-CuSn5ZnPb	B584 C83600
Chrome Steel	1.4021	X20Cr13	A276 Type 420
Chrome Steel(heat treated)	1.4021	X20Cr13	A276 Type 420+QT
Chrome Nickel Steel	1.4301	X5CrNi18-10	A276 Type 304
Chrome Nickel Steel (low carbon)	1.4404	X2CrNiMo17-12-2	A276 Type 316L
Duplex (austenitic-ferritic) Steel	1.4460	X3CrNiMoN27-5-2	AISI 329
Duplex (austenitic-ferritic) Steel	1.4462	X2CrNiMoN22-5-3	UNS S32205

### Flange Dimensions

EN 1092 - 2

DNe/DNb	Suction & Discharge (PN 16)			
	Df	k	s	n
40	150	110	19	4
50	165	125	19	4
65	185	145	19	4
80	200	160	19	8
100	220	180	19	8
125	250	210	19	8
150	285	240	23	8
200	340	295	23	12

" n " number of holes

