

BEDU
≡ POMPEN ≡

Operating and maintenance manual

BG - BZ - BX - MX series



made for your process

USE AND MAINTENANCE OF THE GEAR PUMPS

INTRODUCTION

This operation and maintenance handbook has been drawn up according to EEC 89/392 and UNI EN 292/2.

Like all volumetric pumps, the gear pump has a suction capability and the Bedu pumps, in normal conditions will generate about 7 metres of suction lift.

Ensure that gears do not operate when dry. Before running the pump for the first time or after long stationary periods it is advisable to fill the gear spaces with liquid through one of the ports and to rotate the pump by hand. This also makes it possible to establish if friction in the pump is uniform.

It is recommended that an overload cutout set as 10% above the motor current be installed in the control circuit.

In bare shaft pumps used on low pressures without relief valve and with packing seal the rotation may be in either direction and therefore the symbols SUCTION and DELIVERY are not indicated on the ports.

If there is a relief valve, mechanical seal or canalization for high pressure the rotation must be indicated by the arrows.

The pump operating temperature in normal working conditions is up to 80° C.

In special pump version, working temperatures of 180° C may be achieved.

Liquids to be pumped must not contain abrasive or solid suspensions as this will greatly reduce the pump life.

We recommend a filter of 100 microns should be installed in the suction line if solids may be present.

When pumps are installed in parallel the suction lines should be adequately separated to prevent unnecessary turbulence.

CHAPTER 1

INSTALLATION

1.1 - LOCATION

Locate the pump as near of supply as possible to reduce determinial pipe friction.

Many pump system deliver below the rated capacity of the pump because they are not properly piped. Pipe friction, suction lift, discharge head, vacuum and total pressure should be competed for the specific liquid being handled, and the desired flow rate.

The pipe diameters should be adequate to ensure to that pipe friction losses do not exceed the pump limits, especially when handling viscous liquids.

Avoid wherever possible, sudden restrictions such as changes in pipe sizes, globe valves, undersized strainers or sharp elbows.

The inlet line should be at least as large as the pump intake, and as straight as possible. It is important that there are no air lerks in the intake line. the use of ceck valves in the inlet line is generally not recommended wiht a self priming, positive displacement pump and can cause considerable trouble.

If a valve is closed in the discharge line while the pump is operating it forces liquid to recirculate through the relief valve causing the liquid to heat up and expand so should only be done for very short periods.

1.1.1 FOUNDATION

When installing pumps units built onto baseplates, care should be taken to ensure that the base is not twisted out of shape when anchor bolts are tightened and pipes are connected. Shims may be needed under the base before tightening the anchor bolts.

1.1.2. ALIGNMENT

Where bare shaft pumps are to be installed they must be connected to the driver by a suitable flexible coupling and aligend as shown below.

Where complete pump sets are supplied the alignment of the pump to the motor or geared motor is often disturbed in transit and must be checked before the pump is put into operation on units where flexible couplings are used the coupling guard must be removed and a straight edge laid across the two hubs. The maximum offset should be less than 0.380 mm.

With a feeler gauge check the angular alignment of the coupling halves in four places at 90 degree increments around the coupling. This should not vary by more than 0.500mm.

Check the alignment of the pipes to the pump to avoid strains which might case damage to the pump or later cause misalignment. To check, unbolt flanges and ensure that pipes do not spring away or drop down. After pumps have been in opration for a few weeks rechegek alignment.

If the client must make alignment at later stage then some basic rules must be followed to ensure correct functioning.

The fundamental operations are:

- Accurately measure the height of the pump axis (h) and the height of the engine axis (H).

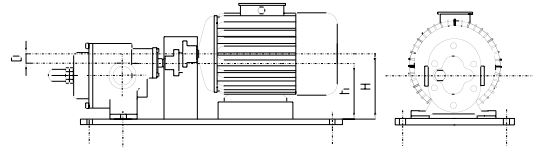

Fig. 1.1.1.A

- Calculate the difference:

$$D = h - H$$

- Prepare alluminium (or steel) shims of thickness **D**.

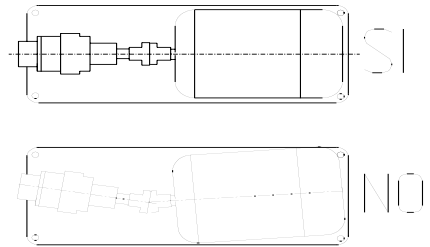

Fig. 1.1.1.B

- Install on a single level base ensuring that the engine and pump are on the same level (fig. 1.1.A), positioning the shims where necessary (either under the feet of the pump or under the feet of the engine).

- Check that the axes of the two shafts coincide, measuring the two diameters by difference

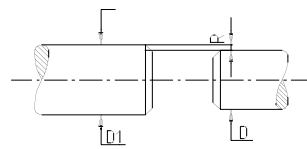

Fig. 1.1.1.C

(Fig. 1.1.1.C.); i.e. accurately measure **R**

$$D1 = 2R + d$$

If these are not exactly the same then place metal sheets shims below the missing parts until the whole is completely level.

- Check that the pump and engine axes are perfectly coaxial (fig. 1.1.B) because any displacement would provoke a radial component causing fatigue stress which would damage both pump and engine.- **The engine block must be fixed (T) onto a rigid support which guarantees a level base** (Fig. 1.1.1.E); otherwise the engine block would be put

understresscausing the consequent displacement of the axes.

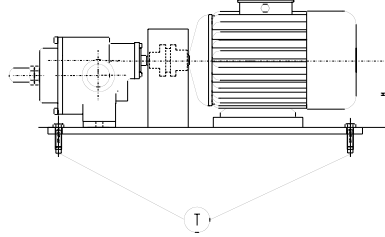

Fig. 1.1.1.E

- Before closing the butt strap, **manually rotate the engine pump coupling** to check that no part increases the friction and stress.
- **Connect the piping to the pump inlets.**
- **Connect the engine to the power supply.**
- **Open the suction and delivery valves.**
- **Turn on the power supply for a moment** to check that the pump rotates in the direction indicated by the arrow on the pump.
- **Start up the pump** and ensure that the pump engages immediately after start up.

1.1.3 GUARDS

Guards must be fitted to comply with the latest European standard EN 349 to protect all moving parts.

It is obligatory to place a guard on the flexible coupling. This guard must be made installed so that it is impossible to have access, either on purpose or by mistake, to the flexible coupling. This guard must be firmly screwed onto the unit.

1.1.4 CONNECTION TO POWER SUPPLY

Connect the engine to the mains, taking care that the engine voltage and plant voltage are compatible.

Start up the pump. Make sure that the rotation direction is correct and that the flow of liquid is regular and uniform after the pump has engaged.

1.1.5 INSTALLATION OF PUMP IN THE PLANT

Single suction

The pump must not have a negative head (suction) of above **7 m** because otherwise it would be

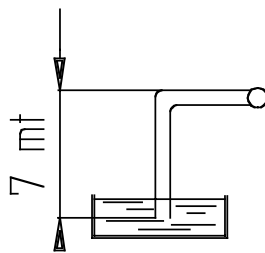

in a critical area for good functioning.

Dual suction

The pump suction pipes must be installed separately. If a system with single suction pipe is installed for two pumps then the pump may not

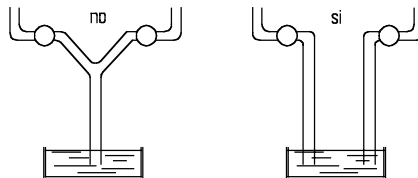

intake when started up because of interference.

Siphoning

A siphon must never be made in the suction pipe because the air bubble created in the pipe would not allow the liquid to flow uniformly or may even

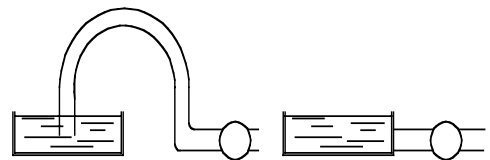

completely block the passage producing a pump cavitation.

Antivibration measures

We recommend the use of vibration dampers below the pump base and vibration damping sections as pipe terminals near the pump (sections which must have chemical characteristics suitable for its use).

1.2 - START UP

- 1) Ensure that the power supply to the pump is switched off.
- 2) Check that the suction pipes are firmly joined so that no air can enter. This would prevent the pump from intaking the liquid.
- 3) Check that siphons are not created in the suction pipes so that the pump can completely remove the air. If the air is not completely removed then the flow rate may decrease and the noise level may increase even although the pump has taken in the liquid.
- 4) Check that the valve is working. To do this remove the external body then, loosening the jam nut, manually rotate the adjusting screw clockwise. A little resistance should be encountered; this indicates the load of the by-pass spring. If the adjusting screw is loose then rotate it clockwise; this loads the spring thrust; otherwise the feeler may not have the ideal seal between suction and delivery.

Before starting up the pump again, remember to re-tighten the jam nut, otherwise air would enter.

Start up the pump and set the operating pressure, ensuring that this is compatible with the installed power.

If the maximum pressure is not the desired one then adjust the by-pass valve. Remember that our valves normally have working range of between 3 and 10 bar.

CHAPTER 2

IDENTIFICATION OF THE PUMP

2.1 - DESCRIPTION OF THE PUMP

The volumetric gear pumps of this series are used to transfer liquid up to 10 Bar.

The standard pumps have:

BG - cast iron body and cover - carbon steel gears and shafts - brass relief valve - self lubricating sintered bush.

BZ - bronze body, cover and gears - AISI 316 stainless steel shafts - brass relief valve - bush as model B.

BX-MX - AISI 316 stainless steel body, cover, gears, shafts and relief valve - rammed P.T.F.E. or graphite bushes.

2.2 - SEALS

Mechanical seal (C) - dual mechanical seal (CC) - packing (B).

It is possible to instal a preheating chamber (CP).

Example of a model:

BZ 100/BCP - bronze pump - flow rate 100 l/min packing seal - preheating chamber.

Type B gear pumps can be aligned on a base to motor with fixed on variable speed reducers.

It is also possible to install an electronic panel with digital impulse counter and proximity contact to dose the same quantity of product (GEAR DOSAGE PUMP).

Special seals

When the viscosity of the pumped product reaches levels where simple mechanical sealing does not function efficiently then there are two possible solutions:

- 1) use packing
- 2) use dual flow mechanical seal

Packing seal

The packing seal is normally used when there is high viscosity and/or high temperatures.

This type of seal (5) normally requires the packing follower (10) to constantly exert pressure so continuous manual pre-loading is needed, by symmetrically tightening the screw (7) of the follower.

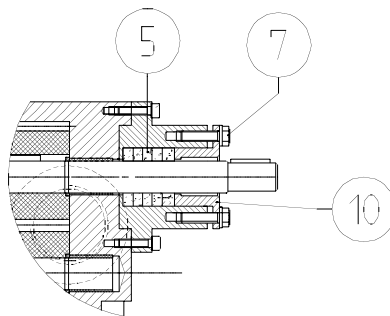

Obviously, when the follower's pre-loading action is completed then the old packing (5) must be replaced. For the packing to function at its best then there must be a slight leakage between the packing and head for lubrication. If this were not the case then the packing would burn very quickly,

causing premature deterioration of the seal and driving shaft system.

Dual flow mechanical seal

To prevent the packing from dripping a mechanical seal must be used. However, if the liquid pumped is viscous then the seal requires external flow. In this case two opposed mechanical seals are necessary.

The internal seal (3) must face the pumping chamber (thus the loading spring alone will counteract the pressure of the pumping chamber)

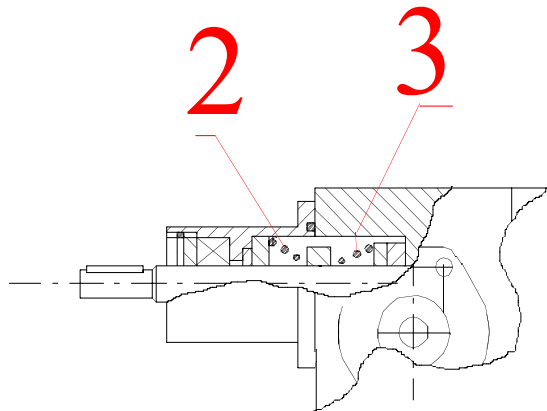

FIG. 2.2.B

while the external seal (2) will only restrain the flowing liquid and will face outwards. it should be noted that when the pump must exert a pressure of above 2 bars, the flowing chamber must have the same, or higher, pressure than that exerted by the pump (ideally 1 bar higher).

2.3 - APPLICATIONS

This series is widely used to transfer oils, naphta, diesels, preheated grease, adhesives, glues, paints, resins, molasses, syrups, shampoo, isocyanates etc.

Flow rate: from 5 to 500 l/min

Pressure: up to 10 bar

Max viscosity: 100,000 cps

Max temp. (on request): 300°C

2.4 - NOISE TEST

When measuring noise, the pumped liquid (ref. to a liquid or 2°E, lubricant) must be introduced into the testing system at a speed of less than 0.8 meters/sec and the ports at a maximum speed

of 5.5 meters/sec. It must however reach laminar flow regime (thus the speed must be related to the viscosity) and the conditions outlined in this handbook must be respected.

Noise was measured at 6 points according to the CEN/TC 197/SC3 N21 (fig. 8) and ISO 3744 standards. The following noise levels were measured:

1. Weighted equivalent continuous noise level $L_{eq} = 74$ dB (A)
2. Maximum weighted instantaneous noise level (peak level) $L_{pc} < 76$ dB (C).

CHAPTER 3 USE OF THE PUMP

3.1 - AUTHORIZED AND UNAUTHORIZED USES

Use

Do not use the pump other than for its intended purpose.

The manufacturer must be consulted if the pump is used for other purposes otherwise the user will be held directly responsible.

Authorized uses

- 1) The pump's uses are outlined in point 2.3.
- 2) In all cases, the materials used to manufacture the pump must be compatible with its use. For this reason the client must specify the safety requirements requested for the use of the liquid to be pumped.
- 3) The liquid must not contain suspended abrasives (solids). See point 1.

3.2 - PRECAUTIONS

- Before any operation, put on glasses, gloves and protective clothing.
- Never open the relief valve when the pump is pressurized.
- Never open the pumping unit when pressurized.
- Before opening any part of the pump proceed as follows
 - turn off power
 - close the suction and delivery valve
 - remove the pump from the system and place a container below the pump to collect the liquid
- carry out necessary operations
- re-assemble the pump into the system
- open the valve
- switch on power

- start up the pump
- never tamper with rotating gears (when inspecting inlets or gears)

- Place a container below the pump to collect the liquid if the seals drip

- If hot liquids are pumped the pump must be left to cool down before opening and point 1 of paragraph 3.2 must be followed.

- If the pump is to be used in explosive environments then the pump must be aligned to an EEX class (flameproof) engine. This engine must be specifically requested.

- The pump base must be firmly fixed to a flat surface, otherwise there may be radial components on the coupling and thus fatigue stress with the consequent premature deterioration of the pump.

- The pump must never be started up when delivery is throttled unless it has a gauged delivery overpressure valve (otherwise the water hammer could damage the pump).

- When a pump is started ensure that the rotation direction is that indicated by the arrow.

- When a flexible coupling is used it must be properly guarded. If there is no guard at the beginning, when establishing the rotation direction, keep at least 2 meters away from the pump.
The machine must not operate without the coupling guard.
The motor must be earthed and have a (thermal) overload cutout .

- Any regulation systems must be installed by the client.

Temperature

The user must install thermal insulation for those uses where the temperature of the body of the pump reaches and/or exceeds the burn threshold.

CHAPTER 4 MAINTENANCE

4.1 - AVAILABILITY AND INDICATIONS REGARDING THE REPLACEMENT OF NORMAL WEAR PARTS

The normal wear parts not included in the guarantee and recommended for spares stock are:

- **Bush**
- **Gears**
- **Shafts**

- **Seal parts** (mechanical seal, packing, seals).

To replace these parts, loosen the socket head bolts which fix the cover and those on the stuffing box. Access is thus given to the gear chamber and stuffing box chamber.

The bolts on the cover must be tightened in a cross-wise way, rotating the pumping unit at the same time in order to avoid different pressures on the gears which may block the pump or increase friction.

The **torque** to be applied on the bolts of our pumps are:

for M6 screws	(11 - 12) Nm
for M8 screws	(20 - 22) Nm
for M10 screws	(38 - 40) Nm

For further information contact our Technical office.

4.2 - ASSEMBLY AND DISASSEMBLY

Replacing driven pinion and bush.

Before starting, **put on gloves, glasses and protective clothing**. In the case of corrosive and/or dangerous liquid the **pumping parts must be washed**.

Then proceed as follows:

- **Switch off power** (Fig. 4.A)
- Close **suction and delivery valve**
- **Disconnect pump** from pipes and baseplate
- **Fix the pump** on a work bench. **Block the pump feet** - do not use a clamp on the body of the pump because this may damage the gear seats.

(fig. 4.2.A)

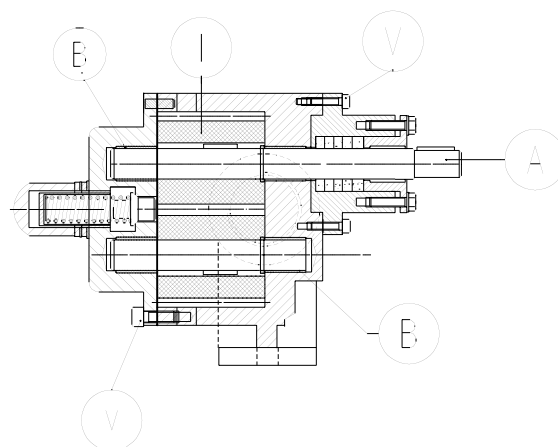

- **Take off the cover** of the cylinder head and mechanical seal by loosening the socket head screws (V) (Fig. 4.B).

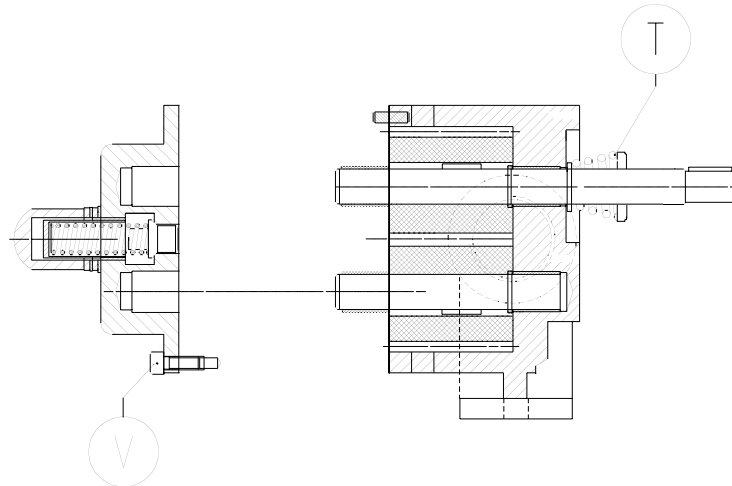

(fig. 4.2.B)

- Remove seals.
- **Remove the mechanical seal (T)**, taking care to ensure that the static part is fixed in the mechanical seal cover.
- **Remove the spacer** (mechanical seal) from the shaft seat.
- **Remove the driving shaft key.**
- **Remove the driven pinion** (Fig. 4.C)
- **Replace the bushes (B)**
- **Re-assemble** following these instructions in the reverse order.

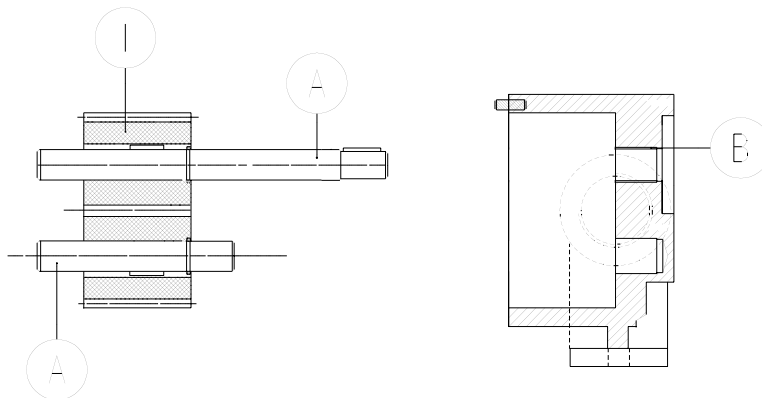

(fig. 4.2.C)

4.3 - MAINTENANCE OF SEALS

Packing seal

- Loosen the two bolts (7) on the stuffing box head and remove the follower (10) from its seat (fig. 4.3.A)
- use a screwdriver to extract the worn packing
- carefully clean the tow chamber ensuring that the shaft has no scoring in the friction area otherwise it must be replaced
- install the new packing and carefully lubricate the area between the shaft and the packing
- replace the packing follow (10)
- compress the packing by alternately tightening the bolts (7)
- replace pump on the baseplate and start up, ensuring that the tightening is such that there is a slight leakage through the packing .

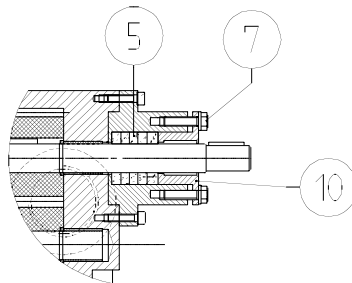

Mechanical seal

- Loosen the two (sometimes 3) fixing screws on the container
- Remove the cover and check the condition of the mechanical seal surfaces
- If worn, remove the fixed by exerting a slight pressure from the back
- Remove the rotating face by hooking the spring with two screwdrivers or two shaped extractors
- Check that the shaft is not scored, otherwise replace it.
- Replace the seal, taking care not to damage elastomers and lapped surfaces
- Close the pump
- Rotate the shaft so that the seal surfaces fit perfectly

When re-assembled on the system the pump must not leak. If there is leakage, when the pump is in action, gently tighten the delivery valve until the mechanical seal fits perfectly.



EC - Declaration of Conformity

Manufacturer Details

Tradename

Bedu Pompen BV

Address

Poort van Midden Gelderland Rood 10, 6666 LT, Heteren, Netherlands

Product Details

Product Name

Gear pumps

Model (+series) Name

BG, BZ, BX, MX

Applicable Standards Details

Directives

2006/42/EC (Machinery Directive)
2014/35/EU (Low Voltage Directive)
2014/30/EU (Electromagnetic compatibility)

Standards

EN-ISO 12100:2010
EN-IEC 60204-1:2006
EN 809+A1/C1

Additional information

No further details.

Declaration

We hereby declare under our sole responsibility that the product(s) mentioned above to which this declaration relates complies with the above mentioned standards and Directives.

Business Unit Manager: Issued Date:

01/10 2014

BEDU Pompen BV

Poort van Midden Gelderland Rood 10
6666 LT Heteren

Tel : +31 (0)88 - 4802 900

Fax : +31 (0)88 - 4802 901

E-mail : info@bedu.nl

Website : www.bedu.eu

Marco Breunissen

Signature of representative(s)

The logo for BEDU POMPEN is centered in a white square. It features the word "BEDU" in a large, bold, white sans-serif font. Below it, the word "POMPEN" is written in a smaller, white sans-serif font, flanked by two horizontal lines on each side.

BEDU
POMPEN

made for your process

- Expert advice
- A customer-oriented organization that adapts to the requirements and wishes of your organization
- Innovative and customized solutions
- Breakdownservice, 24 hours a day, 7 days a week
- Technical service with extensive test facilities, working from our own workplace or at your location
- A fast and appropriate solution for all your issues
- Wide range of liquid pumps
- Repair, maintenance and revision

BEDU POMPEN B.V.
Poort van Midden Gelderland Rood 10
6666 LT HETEREN
Nederland
Telefoon +31 (0)88 4802 900
E-mail info@bedu.eu

WWW.BEDU.EU

BEDU BELGIUM B.V.B.A.
Industriepark-West 75
9100 SINT-NIKLAAS
België
Telefoon +32 (0)3 80 87 980
E-mail info@bedu.be

WWW.BEDU.BE

