

BEDU
≡ POMPEN ≡

Installation, Operation and Maintenance Instructions



Model: close couple pump with electric motor

MAGNETIC DRIVE PUMPS
Centrifugal, horizontal, Lined
C MAG-PL series



Model: Pump



Model: Bare frame pump

made for your process

INDEX

1. GENERAL WARNINGS AND SAFETY	5
2. WARRANTY	6
3. NAMEPLATE	6
4. PUMP DESCRIPTION	8
5. TECHNICAL DATA	8
6. OPERATING AND PERFORMANCE LIMITS	9
1. OVERALL DIMENSIONS	10
2. NOISE AND VIBRATION	10
3. IONIZING RADIATION	11
4. CHECKS TO PUMP DELIVERY, STORAGE	11
5. SHIPPING AND HANDLING	11
6. ASSEMBLY, INSTALLATION, CONNECTIONS, COMMISSIONING AND SETTING	12
6.1. Assembly	12
6.2. Connection of the pump to suction and discharge pipes	12
6.3. Electrical connections;	13
6.4. Checks for the proper operation	13
6.5. Commissioning and operator training	13
6.5.1. Self-priming pumps and non self-priming pumps	14
6.6. Coupling the pump to the motor.....	14
6.7. Features and installation of pump and motor assembly	14
6.8. Alignment of the coupling	14
6.8.1. Alignment tolerances and coupling	15
7. INTENDED USE OF THE PUMP. IMPROPER USE. DESCRIPTION OF FUNCTIONING.PERSONAL PROTECTIVE EQUIPMENT DURING USE	15
7.1. Intended use of the pump.....	15
7.2. Instructions for proper use reasonably foreseeable	15
7.3. Not permitted use.....	16
8. RESIDUAL RISKS AND PROTECTION MEASURES TO BE TAKEN	16
8.1. Description of the residual risks	16
8.2. Protection measures to be taken by the user and instructions	17
8.3. Personal protective equipment to wear	17
9. OPERATIONAL LIMITS, DESCRIPTION OF HAZARDS NOT ELIMINATED FROM THE SAFETY MEASURES TAKEN	17
9.1. Safety informations present on the pump.....	17
9.2. Recovery mode	18
9.3. Fire-fighting equipment to be used:	18
9.4. Emission / dispersion of harmful substances.....	18
10. MALFUNCTIONING, FAILURE, BREAKDOWN, ACCIDENT. MOST FREQUENT PROBLEMS: CAUSES AND REMEDIES ..	18
10.1. Malfunctioning.....	18
10.2. Failure	18
10.3. Breakdown.....	19
10.4. Accident.....	19
10.5. Most frequent problems: problems, causes, remedies, residual risks	19
11. PERIODIC AND EXTRAORDINARY MAINTENANCE	22
11.1. Cleaning components and magnet	22
11.2. Periodic preventive maintenance	22
11.2.1. Emptying of the fluid contained in the pump	23
11.2.2. Emptying the oil contained in the pump.....	23
11.3. Extraordinary maintenance.....	23
12. REPAIR AND PARTS REPLACEMENT	23
13. PERIODIC AND EXTRAORDINARY MAINTENANCE"	23
13.1. Pump disassembling	23
13.2. Pump disassembling	24
13.3. Pump reassembling	27
14. DECOMMISSIONING, DISMANTLING AND DISPOSAL OF MATERIALS	27
14.1. Decommissioning.....	27
14.2. Demolition and dismantling	27
15. EXPLODED VIEW PART LIST	28
16. NOTES	29
17. APPENDIX A – Register of maintenance and periodic checks of the pump	29

1. GENERAL WARNINGS AND SAFETY

This manual has been prepared by *Bedu Pompen* pump to provide the user all necessary information for its proper use and regular maintenance. Together with this manual you will find the manual of the electric motor when the pump is supplied with motor.

For health and safety at the workplace and to ensure a fair and sustainable use of the pump, the manual should be kept for any consultation.

As part of the pump, this manual must be kept at all times.

For any data not included or not deductible from this manual it is recommended that you contact *Bedu Pompen*.

Do not use the pump before you have read and understood all safety rules and instructions in this manual.

In case of damage or loss of the manual, ask for a copy to *Bedu Pompen* immediately.

The failure to follow instructions in this manual, exempt *Bedu Pompen* from any liability.

The pump and the instructions are intended for operators who make professional use and should be used by qualified personnel adequately trained, aware of the application, operation and risk that the pump generates during its use, the user with experience is the best form of qualification.

Bedu Pompen reserves at any time the right to make changes deemed necessary to improve the pump, taking care to update this manual as soon as possible. This reflects the state of the art when the pump was sold. In case of transfer of the pump, the user is encouraged to report to *Bedu Pompen* the address of the new owner to facilitate the transmission of any additions to the manual to the new user.

Bedu Pompen reserves all rights to this manual, no total or partial reproduction is allowed without written permission.

Symbols used in the manual.

Along the manual, warning signs will be found, to indicate possible dangerous and risky situations. These safety warning signs consist in a symbol and the respective warning.

MAGNETIC



Persistence of a magnetic field. This field may represent an immediate danger to individuals who have electronic medical devices, metal heart valves, metal or any other metal objects, impairing its functionality.

Bedu Pompen declines any responsibility for any damages to people who did not keep a safe distance of at least 1metre, where it is shown that symbol

DANGER



Indicates a potential risk to operators who are using the pump and / or the integrity of the pump, which could result in damaging itself and / or serious injury to people concerned.

CAUTION



Demands full attention to important details that the staff must know and keep in mind for the proper use and operation of the pump.

PROHIBITION



Demands full attention to operations or manipulations that are absolutely forbidden, not respecting the prohibition may damage the pump and / or operators.

Failing to observe these prohibitions releases *Bedu Pompen* of any responsibility for damages to things and/or people.

2. WARRANTY

Valid for one year from the date of the pump sale. *Bedu Pompen* do not assume any liability for any warranties explicit or implied, nor as regards the possibility to sell or the suitability of the items supplied.

The warranty will not be applied if:

- the repair and / or maintenance was not carried out strictly in accordance with the instructions;
- the pump has not been installed and put into service as instructed;
- the repairs were not made by staff *Bedu Pompen* or were made without consulting *Bedu Pompen*;
- not original spare parts were used;
- used lubricants were different from those recommended;
- the parts supplied were not used according to their nature and / or destination;
- the parts supplied were used carelessly, negligently, improperly;
- the parts supplied were damaged due to external circumstances.

All wear parts are excluded from warranty.

3. NAMEPLATE

The pump for installation in ordinary environments has the nameplate on the side of the support as shown: only the compiled fields must be considered relevant and therefore valid for identification.



The serial number of the pump, here called serial number (s.nr) defines the type of components installed in the pump:

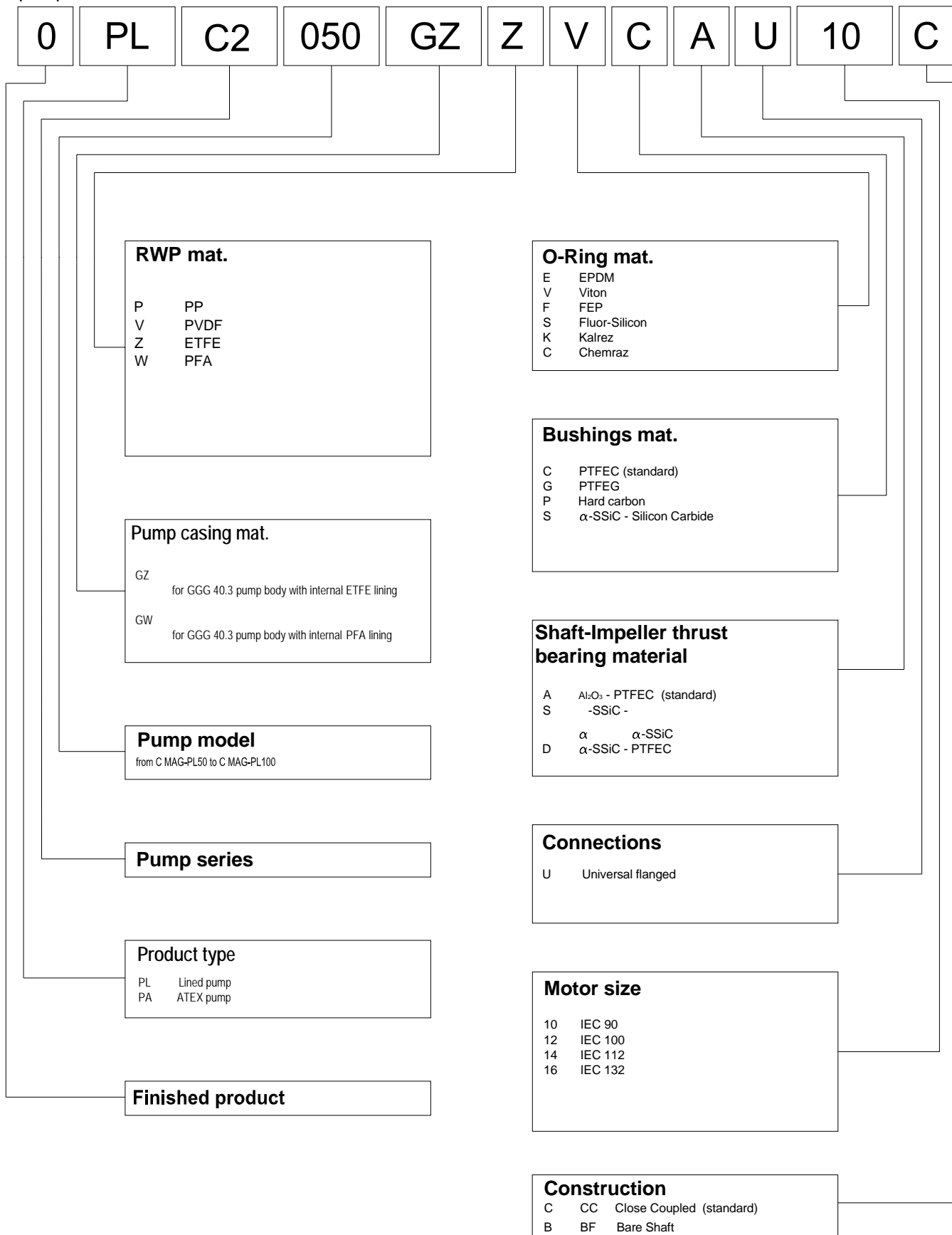

4. PUMP DESCRIPTION

Key feature of magnetic drive pumps is that the fluid that has to be pumped never comes into direct contact with engine parts, ensuring the physical separation between the motor and the pump and the transmission is delivered via a coaxial magnetic coupling.

The pump consists of a part (outer rotor) that is coupled to an electric motor through elastic coupling (bare shaft version) or directly (close coupled) and a part (internal rotor integral with the pump impeller) that allows fluid pumping. The outer rotor consists of a series of magnetic elements with variable features and size suitable to the torque to be transmitted. The inner and outer rotor magnets are a magnetic circuit, characterized by overlooked opposite polarity pairs. At electric motor start, the outer rotor, when rotating, drives synchronously the internal rotor, thus the power is transmitted to the pump impeller that explains the liquid pumping contained in the pump body. A static containment shell, called rear casing, located between the two rotors, separates the liquid from the atmosphere, making the pump hermetic.

Applications:

- Generally this model is ideal for clean liquids slightly contaminated, without particles that can be magnetized;
- The maximum working pressure of the plant, the allowable temperature and the maximum rotation speed depends on the type of pump and it is specified in the "TECHNICAL DATA" paragraph. Other uses are not allowed as the conditions of use stated in the "TECHNICAL DATA" paragraph must be respected in full. Using the pump in a plant or in liquid conditions different from those for which the pump was designed, can lead to dangerous situations to the user.

5. TECHNICAL DATA

The pumps described in this manual has the following characteristics:

Available in bare shaft configuration or close coupled , with the motor directly mounted in the pump support.

C MAG-PL

- Nozzles: Universal Flanges, in compliance with standard DIN PN16, ANSI B 16.5 150lbs;
- Max. Viscosity: 200 cps;
- Max system pressure: 16 BAR
- Flow up to 140 mc/h;
- Head up to 44 m;
- Working temperature from -40°C to 90°C °C for PP and PVDF version, from -50°C to 120°C for PFA version
- Installed motor power: from 2,2kW to 15kW
- Speed: up to 3500 rpm;
- Weight (pump only): from 16 to 110 kg;

Electric Motor characteristics:	Supply frequency: 50 Hz	Supply frequency: 60 Hz
2 poles	2900 rpm	3500 rpm
4 poles	1450 rpm	1750 rpm

CAUTION



- CAUTION: If the pump is driven by inverter, remain within the recommended limits of rotation

6. OPERATING AND PERFORMANCE LIMITS

C MAG-PL

Curve N°: 10672	1450 RPM
-----------------	----------

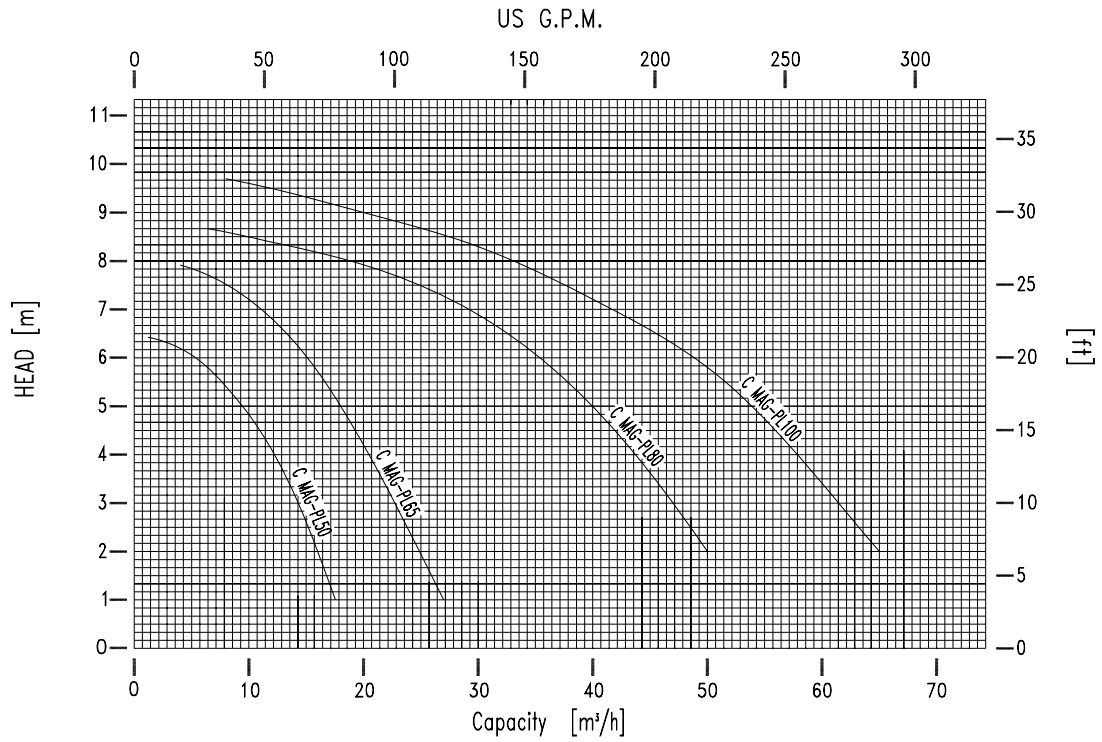

Curve N°: 10672	2900 RPM
-----------------	----------

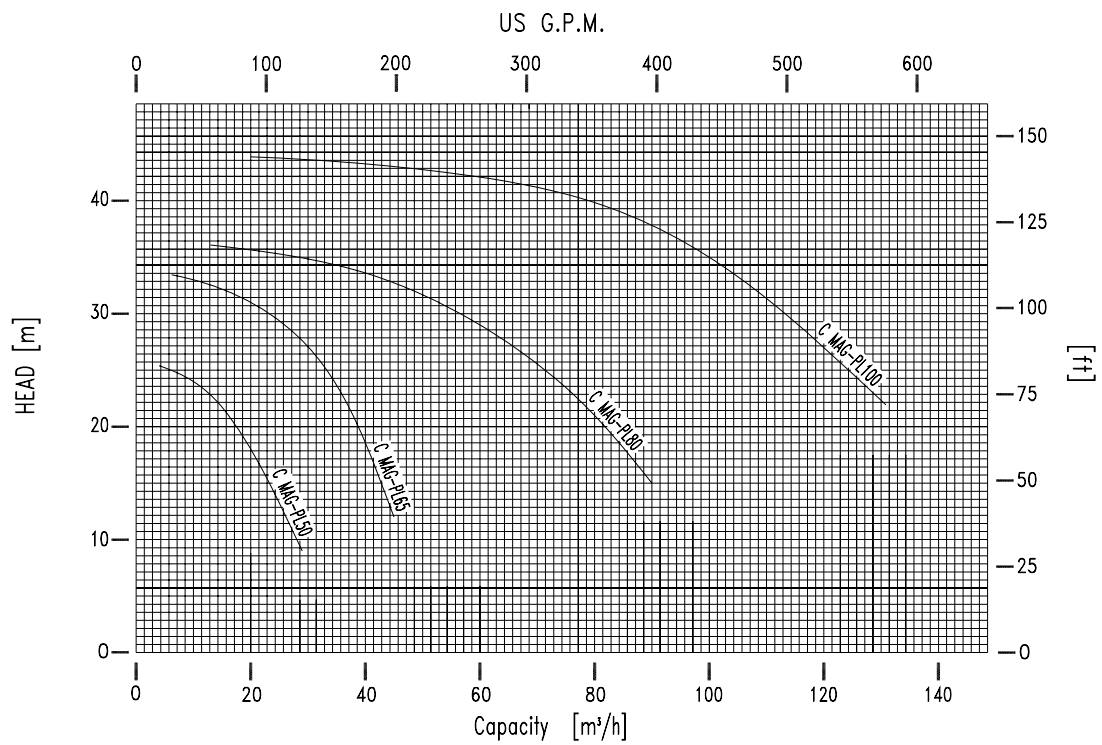

Outlines drawings

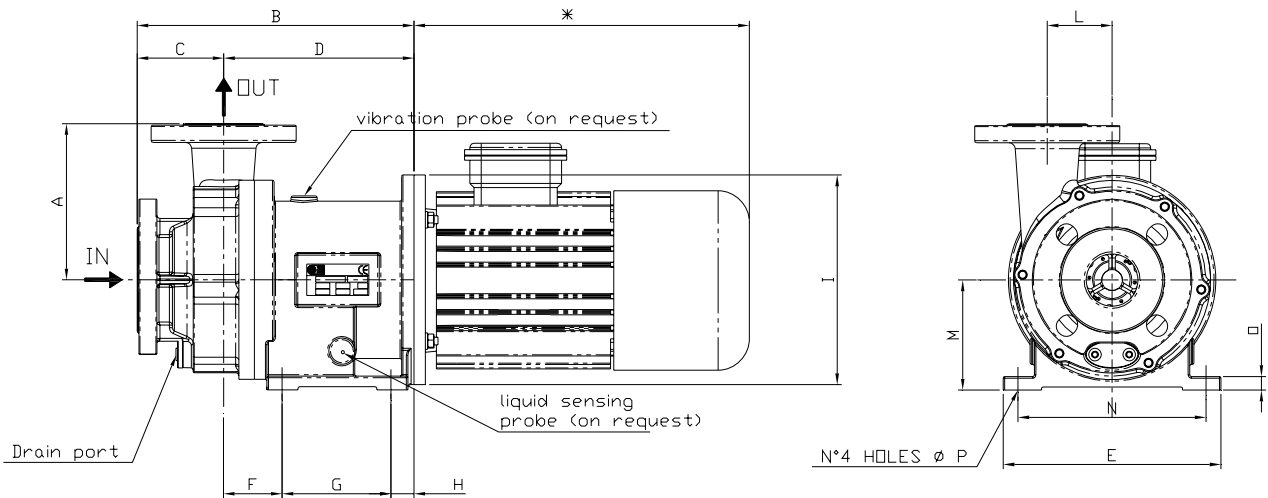

conessioni flangiate Flanged connection														
Aspirazione Suction						Mandata Discharge								
Modello Pompa Pump Model	S	T	U	V	Z	n°	Modello Pompa Pump Model	S	T	U	V	Z	n°	
C MAG-PL 50	50	120.6	125	154	19	4	C MAG-PL 50	40	98.4	110	140	19	4	
C MAG-PL 65	65	145	145	185	19	4	C MAG-PL 65	50	120	125	154	19	4	
C MAG-PL 80	80	160	160	225	19	8	C MAG-PL 80	65	145	152	186	19	4	
C MAG-PL 100	80	160	160	225	19	8	C MAG-PL 100	DIN PN16 o ANSI 150lb (Vedi sotto) DIN PN16 or ANSI 150lb (See below)						

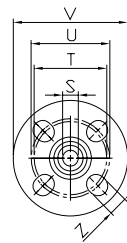

Mandata C MAG-P100 C MAG-P100 Discharge											
Mandata flangiata DIN PN16 Discharge Flanged DIN PN16						Mandata flangiata ANSI 150 lb Discharge Flanged ANSI 150 lb					
Modello Pompa Pump Model	S	T	U	Z	n°	Modello Pompa Pump Model	S	T	U	Z	n°
C MAG-PL 100	80	160	192	18	8	C MAG-PL 100	80	152.4	192	19	4

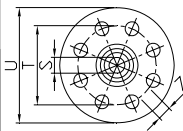

Modello Pompa Pump Model	Gr. motore Motor Size	A	B	C	D	E	F	G	H	I	L	M	N	Ø	P
C MAG-PL 50	90	149	267	83.5	183.5	210	56.7	106	20.8	200	62.5	105	180	13	11
C MAG-PL 50	100/112	149	277	83.5	193.5	220	53	120	21	250	62.5	135	180	15	11
C MAG-PL 65	100/112	171.5	320.5	103	217.5	250	80	100	37.5	250	73	135	210	15	14
C MAG-PL 65	132	171.5	340.5	103	237.5	250	80	120	37.5	300	73	153	210	15	14
C MAG-PL 80	132	198	367.5	121	246.5	250	89	120	37.5	300	82	153	210	15	14
C MAG-PL 100	160	227	408.5	128.5	280	290	92.5	150	37.5	350	102	180	250	20	14

1. OVERALL DIMENSIONS

See specific documentation provided with this manual.

2. NOISE AND VIBRATION

The pump noise depends primarily on the operating conditions. The operating condition of the pump during the measurements is: pump coupled to an electric motor on a bench pumping liquid.

The average sound level measured frontally and laterally to the pump is below 85 dB (A).

3. IONIZING RADIATION

The pump does not emit any kind of ionizing radiation that could endanger persons.

4. CHECKS TO PUMP DELIVERY, STORAGE

All *Bedu Pompen* pumps are tested before shipment and carefully packed for transport: at the reception of the pump make sure that the pump has not been damaged during the transport. If there are problems, contact immediately the carrier and inform *Bedu Pompen* about what happened.

So that the pump is preserved over time as best as possible, we recommend storing it away from the sun, bad weather and dust, if not immediately installed or used for long periods.

Suction and discharge connection safety plugs must not be removed until installation. If provided with electric motor, observe also the motor manufacturer's storage formality.

The maximum allowable temperature range during storage, preservation and use must be between -15 e +40 °C with humidity between 10 e 90%.

5. SHIPPING AND HANDLING

You should carry out a precautionary check when receiving the pump to detect and report any damage in the transport and handling operations. In case of damages do not proceed with any operation but contact immediately *Bedu Pompen*.

The precautions to ensure the stability of the pump concern the possible slips and overturning caused by handling and transport, which must be prevented by setting the pump casing of the pump with ropes to the vehicle frame.

Pump and motor assembly cannot be moved manually due to its high weight.

To move a pump positioned on a pallet, widen as maximum as possible the forks and then operate.

For a stable lifting the pump can be lift as indicated in the figures:

Pump without motor

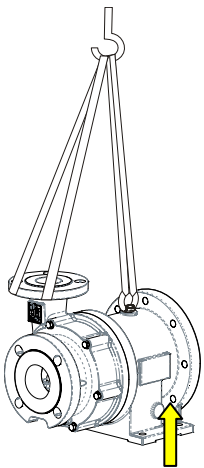

Centre of gravity
approximately in the middle

**Close couple pump with
motor**

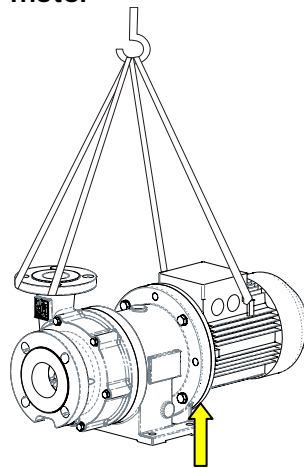

Centre of gravity
approximately in the middle

**Long Coupled Pump
with motor and base plate**

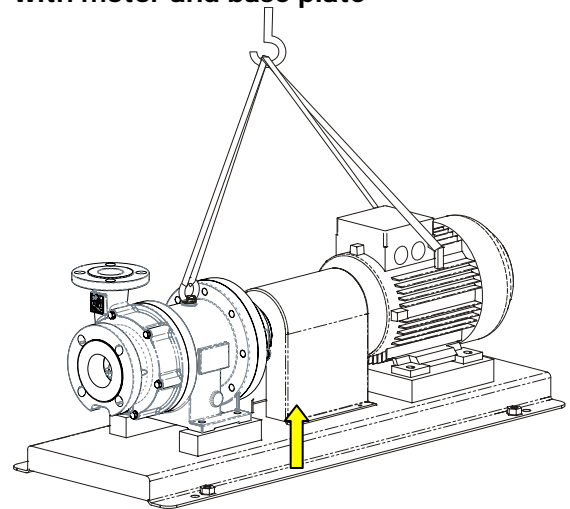

Centre of gravity approximately in the middle

These operations must be performed by a trained staff who is informed of the risk of these procedures.

PROHIBITION



- It is forbidden to lift the pump using different lugs than those specially designed and reported, as points of anchorage.
- You can not lift a pump and motor assembly using the eye-bolt of the electric motor only.
- During the lifting the entire surrounding area is considered as a danger zone and must be cleared by personnel not engaged in those operations.

It is indicated the possibility of transporting and handling the pump using the lugs designed for that use: you must ensure that chains and shackles are able to withstand the weight of the pump (as shown in "TECHNICAL DATA").

6. ASSEMBLY, INSTALLATION, CONNECTIONS, COMMISSIONING AND SETTING

6.1. Assembly

Install the pump on a solid foundation as close as possible to the pumped liquid source, below its level, in a position to facilitate maintenance and inspection.

Ensure that the pump does not take rough shacks as this may damage the magnets of the internal and external rotor or the silicon carbide bearings.

Ensure that the heated air from other units does not affect the pump; the air temperature must not exceed 40 °C, for higher temperatures contact your distributor *Bedu Pompen*, ensure also cooling air free circulation area of at least ¼ the motor diameter, because either the pump or the motor should be able to dissipate the heat by natural air convection. Insufficient cooling could lead to high surface temperatures of the bearings support, poor lubrication and premature failure of bearings. Monitoring of the surface bearings temperature is useful. It is always responsibility of the operator to keep limited the temperature of the liquid to avoid pump superheating: in case of irregular pressure fluctuations and flow drop turn off the pump.

CAUTION



- Normally you should mount the pump horizontally. If mounted vertically or inclined, the pump, or rather the suction flange shall be placed in the lowest point. Leave a space of at least 50 cm between the pump and any walls or pipes.
- When pumping liquid can reach high temperatures: from 60 °C upwards you must install protections to prevent contact with hot pump parts;
- Connect to the ground the entire pump casing to prevent accumulation of static electricity;
- If the pumped liquid can be dangerous to people and environment, the user must take precautions for a simple and quick block in case of leakage for breakage/ replacement/ pump maintenance.

6.2. Connection of the pump to suction and discharge pipes

For a proper installation aimed at an optimal use of the pump, you must follow these requirements:

- pipes must be supported and kept in line independently of the pump, until its connections, so that do not load on it;
- connections must not be subjected to stresses during operation;
- the maximum allowable forces and moments on flanges shall not exceed those listed in "technical data";
- inlet pipes should be built with as few restrictions as possible in order to have the highest available NPSH;
- the length of pipes , particularly that of the inlet pipe must be minimized;
- the pipe must be placed so that it is not possible the formation of air traps; if this is not possible, it should be calculated the possibility of bleeding the air from the highest point ;
- in the suction line use full section valves only;

- if the suction pipe is larger than the suction flange, you must use an eccentric reduction to the suction flange, in order to prevent formation of air traps and vortexes;



NO



YES

- if there is a possibility that the maximum working pressure can be overcome, for example due to excessive suction pressure, appropriate measures should be taken by including a safety valve in the pipe;
- Avoid using quick-closing valves, because sudden changes of pressure cause water hammer very dangerous for the pump and the pipes;
- Before installing the pump, make sure that the suction line is clean and/or provided with a filter to protect the impeller and the bearings from damages incurred by slag, or other foreign particles, especially when you start the installation for the first time.

6.3. Electrical connections:

DANGER



The pump is **supplied with or without electric motor: only qualified personnel** should carry out mechanical connection of the pump to the motor (for the model without motor) and the electrical connections of the motor to the electrical system. Please read carefully the instructions manual of the manufacturer of the motor before you complete the installation.

Make sure that the motor can not be started during maintenance jobs.

6.4. Checks for the proper operation

We recommend installing a **pressure gauge** on both inlet and outlet pipes to allow the operator to easily control the proper pump operation in relation to the required operating point: in case of cavitation or other malfunctions, there will be obvious pressure fluctuations.

Check the differential pressure of the pump between the suction and discharge connections to verify that it works in the required working point.

Check that the absolute pressure at suction is not as low to cause cavitation.

CAUTION



Pump suction absolute pressure (in m) must be at least 0,5 to 1 m higher than the vapour pressure of the pumped liquid, in order to avoid cavitation. Cavitation must always be avoided as it is very dangerous for the structure of the pump.

6.5. Commissioning and operator training

- Fully open the inlet valve and fill the pump and suction line;
- Ensure there are no obstacles to the free rotation of the pump impeller.

The *Bedu Pompen* series C MAG-PL are **not reversible** so the rotation can not be reversed.

The proper **direction of rotation is clockwise**: seen from the pump casing, an arrow indicates the correct direction of rotation; reversing the direction of rotation may cause damages to the pump.

To control the direction of rotation, start and stop immediately the electric motor, then observe the direction of rotation.

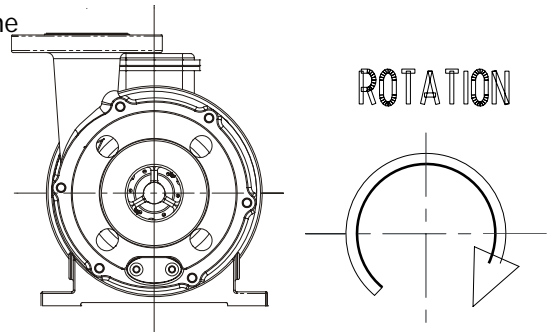

Make sure that rotating parts, such as flexible coupling or other related organs, are always protected when the pump is running.

Operators using the pump must have read this manual in the sections committed to the functioning, use and maintenance, as well as being qualified to fully understand the features and to be able to identify the problems of the pump.

By carrying out the functions mentioned in the previous section and all controls listed in the register maintenance, the pump is ready for use.

6.5.1. Self-priming pumps and non self-priming pumps

C MAG-PL pumps are not self-priming: make sure that the pump is filled with liquid and if necessary, vented before starting; in case that the suction head is negative compared to the discharge, the dry run should be avoided.

6.6. Coupling the pump to the motor

If the pump and the motor are to be coupled, follow strictly the sequences below to proceed with the assembly:

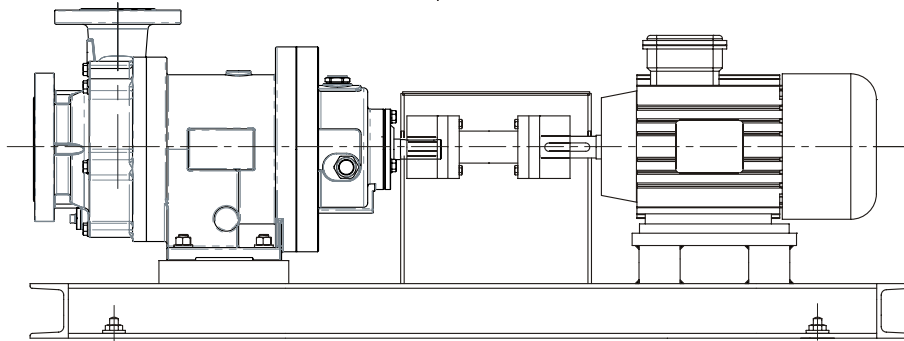

Fit the two elastic coupling halves on the pump and on the motor.

Position the pump on the base plate, insert thicknesses (ca. 5 mm) under the pump and bearing frame feet, then block them with the required bolts.

Place the motor, regulating the thicknesses under the feet, so that the two shafts (pump and motor) are coaxial.

Leave a space of 3mm between the two elastic coupling halves, and then block the motor with the bolts provided

6.7. Features and installation of pump and motor assembly

The shafts of the pump and the motor have already been adjusted and aligned as an extension of one another.

For installation in the plant it is necessary to respect the following sequence:

- The base plate must be anchored to an horizontal base, using also thickness;
- Tighten the nuts of the bolts;
- Check shaft and motor alignment and repeat alignment procedures if necessary (described in the paragraph "Alignment of the coupling").

6.8. Alignment of the coupling

- Place a ruler or straight level on the coupling. Insert or remove any thickness necessary to bring the motor at the correct height, so that the bottom edge of the ruler is placed even on both halves of the coupling along the entire length;
- Repeat the same check on both sides of the coupling, at the shaft level. Turn the motor shaft so that the bottom edge of the ruler touches both halves of the coupling along the entire length;
- Reinstall the protection.

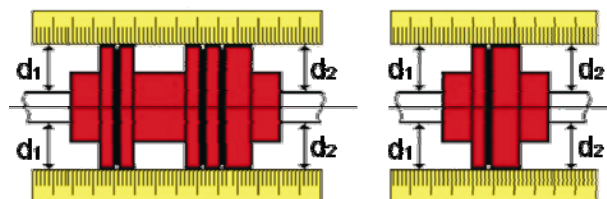

6.8.1. Alignment tolerances and coupling

The maximum allowed tolerances for the two halves alignment of the coupling, to be verified with the comparator, are:

TYPE OF COUPLING	OFFSET	ANGLE
Short flexible coupling (3000 rpm)	0.05mm	0.04mm for coupling with diameter 100mm.
Flexible coupling with spacer (3000 rpm)	0.07mm for spacer 100mm.	0.04mm for coupling with diameter 100mm.

ANGULARITY

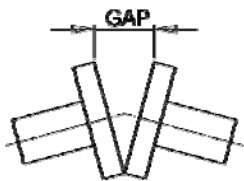

Take care to the angularity
of the coupling faces

OFFSET

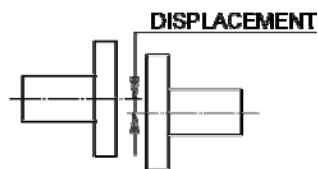

Check the offset between
the shaft axes

7. INTENDED USE OF THE PUMP. IMPROPER USE. DESCRIPTION OF FUNCTIONING. PERSONAL PROTECTIVE EQUIPMENT DURING USE.

7.1. Intended use of the pump

The magnetic drive pump, thanks to the separation between the pump head and the motor, never enters into direct contact with motor parts, providing a friction effect on the impeller of the pump. The pump works correctly if the parameters specified in the paragraph "TECHNICAL DATA" are followed.

7.2. Instructions for proper use reasonably foreseeable

Before starting to operate you must check that:

- All maintenance actions were properly carried out according to the time intervals set by *Bedu Pomper*;
- There are no damaged parts of the pump;
- All the warning stickers and safety plates are present and in good condition and are operating the emergency stop buttons (check through a test).

CAUTION

At the start, immediately check the pressure gauge placed in the discharge: if the discharge pressure does not reach the nominal value quickly, stop the pump and try to start again. Check the pump and piping to make sure that there is no leakage of liquid from the plant. A noisy pump is a symptom of a malfunction that will mean a failure in the short term. A very low frequency noise with a rumble can indicate cavitation; an excessive noise of the motor can be caused by a wear of a bearing.

7.3. Not permitted use

Even maintaining the conditions of use indicated in the paragraph "TECHNICAL DATA", the ways in which the pump should not be used are given here. To avoid damaging the pump, it is forbidden to use it in the following conditions:

PROHIBITION

- Start the pump dry: the pump casing must be full of liquid.
- Run the pump dry for more than one minute;
- Run the pump with inlet valve and /or outlet closed: the heat generated by the impeller, by magnetic coupling and bearings will bring liquid to boil, which will cause pump cavitation/vibration, impeller damaging and bearings collapse;
- The pump flow must never be throttled by the valve located in the suction pipe, which must be kept fully open.
- Start the pump if there are leakages;
- Change working conditions of the pump without having consulted *Bedu Pompen* technical office;
- Loosen pump connections while pump under pressure;
- Try to clean the pump while it is running;
- Run the pump in the opposite direction to that shown in the pump casing;
- Run the pump over nominal temperature and pressure;
- Pumping liquids containing ferromagnetic particles of any size, or substances that can attack chemically or erode the inside of the pump;
- Remove guards and shelters while the pump is running;
- Make any intervention on the pump organs
- Make any intervention on electrical parts installed without first cutting electric power off, do not alter the safety devices installed, do not activate repeatedly the command buttons.

DANGER

It is incorrect any use of the pump other than that mentioned in the paragraph "Instructions for a proper use reasonably foreseeable".
Bedu Pompen disclaims any liability damages to things and people related to uses for which the pump was not specifically designed and constructed.

It is also forbidden to use the pump in a way that, based on experience and under certain situations, may result dangerous situations due to an improper use of the pump.

8. RESIDUAL RISKS AND PROTECTION MEASURES TO BE TAKEN**8.1. Description of the residual risks**

Despite adopted measures incorporated in the pump, the main dangers associated with the use of the pump and the solutions identified are the following:

- Danger of spray projection of process fluid that can be corrosive or burning, as a result of improper installation and sudden ruptures of the pump casing and hydraulic lines;
- Danger of cuts to the hands due to the presence of smears on the pump casing;
- Explosion of the pump due to a formation of explosive mixture inside the pump casing as a result of an improper use.

8.2. Protection measures to be taken by the user and instructions

PROHIBITION



It is absolutely forbidden to the user to tamper safety devices. Before using the pump check the proper anchoring of all mechanical safety protections. Any tampering cancels the warranty and liability of *Bedu Pompen* in front of the pump users.

Only authorized maintenance personnel can perform maintenance operation affecting safety devices.

8.3. Personal protective equipment to wear

Protection measures that have to be taken during this phase are: use of anti acid and antistatic clothing, chemical-resistant glasses, mechanical and chemical protecting gloves and safety shoes. Avoid the use of accessories (necklaces, bracelets, etc.) and unshackled, torn or dangling clothes that could get entangled in parts of the structure.

9. OPERATIONAL LIMITS, DESCRIPTION OF HAZARDS NOT ELIMINATED FROM THE SAFETY MEASURES TAKEN

Dangers that have not been reduced/ eliminated with the safety measures adopted on the pump can be reduced/eliminated if operators apply management measures such as:

- Keep all the safety warnings of and all stickers and labels intact and replace them when necessary, periodically checking their good condition;
- Do not consume substances which may affect the physical ability or the mental faculty (alcoholic beverages, medicines, drugs, etc);
- Always use original spare parts or components approved by *Bedu Pompen*;
- Always perform any modification or structural intervention without the approval of *Bedu Pompen*;
- After accidental shocks suffered by the pump, check the pump integrity and perform a check to *Bedu Pompen*;
- After a long shut down period of pump, check pump integrity and wearing parts status. If necessary replace them with original spare parts.

CAUTION





Each of the misuse or negligence listed up to now causes:

- immediate cancellation of *Bedu Pompen* warranty.
- cancellation of *Bedu Pompen* responsibility for damage to property, animals or people.

9.1. Safety informations present on the pump

Safety warnings applied to the pump must be respected and restored in case of illegibility, and are as follow:

Warning	Description signs applied	Symbol/indication	Quantity	
1.	<i>Bedu Pompen</i> nameplate.	As described in paragraph "PLATE"	1	Replace it if illegible
2.	Label rotation and do not run dry indication		1	Replace it if illegible

Warning	Description signs applied	Symbol/indication	Quantity	
3.	Hydro-test label		1	Internal use
4.	Label quality control assembly		1	Internal use

INSTRUCTIONS AND PROCEDURES FOR THE TRAINING OF THE PERSONNEL AND FOR EMERGENCIES

Operators responsible for the various life stages of the pump must be:

- for assemblers: staff formed and trained on good practices for handling of goods with the use of tools and lifting equipments;
- for installers of pipes and electrical connections: qualified and trained staff to operate on electrical plants, staff with experience in hydraulic installations;
- for users: professional staff trained in the instruction for use of this pump.

In case of emergency:

- alert who is close to the situation of danger, even waving his arms;
- stop the pump by pressing the nearest emergency stop button;

9.2. Recovery mode

To return to normal operating conditions, you must identify and eliminate all causes that have provoked the emergency, eventually repairing or replacing the components that may have been damaged.

CAUTION



After the intervention on protection devices, it must be found the cause that provoked it before continuing to operate.

9.3. Fire-fighting equipment to be used:

In case of fire involving the pump, you can use water or liquid foam or powder type fire extinguisher, but only after shutting off electric power. Do not use CO2 as sprayed at -79 ° C may react violently with hot parts.

9.4. Emission / dispersion of harmful substances

The fluid in the plant might be released in the atmosphere following an intervention or the pump break.

10. MALFUNCTIONING, FAILURE, BREAKDOWN, ACCIDENT. MOST FREQUENT PROBLEMS: CAUSES AND REMEDIES

10.1. Malfunctioning

There are not pump components that may lead to cases of pump malfunctioning as to restrict or make its use dangerous.

In paragraph "Most frequent problems: causes and remedy" is discussed in details in this section.

10.2. Failure

In case of failure of mechanical parts you must immediately restore the original terms of safety by replacing or repairing the parts that have deficiencies.

In case of failure of the pump, proceed as follows:

- Turn the motor off;
- close the inlet and outlet valves;

- find the cause of the failure by checking the section " Most frequent problems: problems, causes, remedies, residual risks".

The failure of a pumping plant can be attributed to:

- a pump failure;
- a failure or defect in the piping;
- a failure due to a miss installation or a start up not correctly made;
- wrong choice of pump.

10.3. Breakdown

In the event of pump failure alert verbally the staff present in the nearness the breakdown status of the pump.

10.4. Accident

In case of accident, you must report the emergency to the plant manager responsible of the installation, in order to secure the plant and allow the emergency team to reach the place where the accident happened.

10.5. Most frequent problems: problems, causes, remedies, residual risks

INSUFFICIENT FLOWS	
Causes	Remedies / actions to be taken
The required head exceeds the designed pump head.	Increase the speed rotation if possible. Fit an impeller of greater diameter Reduce the total head of the system if possible. Increase the diameter of the discharge pipe. Check that the discharge valve is fully open. Replace the pump. Ask for advice to your <i>Bedu Pompen</i> distributor.
The pump rotate in the opposite direction.	Check the direction of rotation. Refer to section 3.5 of this manual
Air or steam trapped in the suction.	Check the presence of air or steam trapped. Refer to section 3.4 of this manual.
The liquid contains air or steam. The liquid produces foam.	Check the presence of vortices in the suction line. Enter some in the fuel tank to prevent the formation of vortices. Install a tank of sufficient capacity in the suction line to allow gas to drag.
Insufficient inlet pressure, with the generation of cavitation and efficiency loss.	Reduce negative suction head, increase static suction height Check that the intake is not blocked or are no bottlenecks. Reduce liquid temperature. Increase suction pipe diameter. Reduce inlet pipe length. Open the inlet valve fully. Check the viscosity of the liquid; refer to "technical data" section of this manual. Increase the temperature of the liquid if necessary.

Wear on pump casing or impeller wear ring.	Check the condition of wearing rings and collar. Replace if worn; refer to Chapter 10 of this manual.
Liquid temperature close to boiling point	Reduce liquid temperature.
NO FLOW	
Causes	Remedies / actions
The pump is not primed	Re-prime the pump. Refer to section 3.5.1 of this manual. Check for air leaks in the suction line
Suction line blocked	Ensure that there are no obstructions, blind pipes, or closed valves. Reduce flow: partially close the discharge valve. If possible reduce liquid specific gravity. Reduce the pump head (check in advance with your distributor <i>Bedu Pomper</i>).
The magnetic coupling decouples	Make sure the pump turns freely; inspect the inside in case this does not happen. Reduce installed motor power (check in advance with your distributor <i>Bedu Pomper</i>). Adopt star-delta starting.
Motor has stop	Check power of the motor. Check status of the motor.
EXCESSIVE FLOW	
Causes	Remedies / actions
The head required is lower than that provided by the pump	If possible, reduce rotation speed reduce the impeller diameter; partially close the discharge valve .
OVERHEATING OR MOTOR STOP	
Excessive liquid specific gravity.	Reduce flow by throttling discharge valve.
The pump has seized or is about to seize.	Check the free rotation of the impeller. Check for internal obstructions.
The motor and pump are misaligned.	Refer to section 3.8 of this manual.
The motor bearings are damaged or worn.	Replace the motor bearings, investigate the causes of breakage.

Motor under dimensioned.	Fit a powerful motor (check in advance with your distributor <i>Bedu Pomper</i>).
Motor overload threshold set incorrectly.	Check motor safety settings.
The motor dry running protector (where present) has failed or has been set incorrectly.	Check flow decreases or lack of liquid in suction.

ANOMALOUS NOISE RUNNING AND/OR VIBRATIONS

Causes	Remedies / actions
Insufficient inlet pressure, consequent cavitation, insufficient lubrication of the bearings (with mechanical damages if the condition persists).	Refer to paragraphs 3.4, 3.5, 4.1, 4.2, 4.3 of this manual
STOP THE PUMP IMMEDIATELY !	
Wear, erosion and immediate damage to the impeller and internal bearings.	Check inside the pump damages or obstructions.
Wear of the coupling motor-pump	Replace the coupling and proceed to the realignment of pump and motor.
Ball bearings or motor failure.	Check and replace them if necessary.
Pump, motor or base plate not anchored well.	Make sure that the motor and base plate are firmly anchored to foundations and do not produce any abnormal vibration.
Misalignment or improper anchoring of the pipes.	Check correct alignment of pipes and supports; refer to section 3.2 of this manual.
The pump was started while still rotating in the opposite direction, for a previous start.	Stop immediately the pump and drain all the liquid from the discharge line before restarting.

OVERHEATING OF EXTERNAL BEARINGS (bare shaft versions)

Lack of oil or wrong type of oil in the bearing frame.	Check oil level: fill up or empty and replace it if necessary. Replace the bearings.
Excessive oil temperature into the bearing frame.	Fill the bearing frame with oil as indicated in the paragraph to restore the correct working temperatures.

11. PERIODIC AND EXTRAORDINARY MAINTENANCE

Proper maintenance and correct use are essential factors to ensure performance and pump lifetime.

11.1. Cleaning components and magnet

To degrease and clean all surfaces of the couplings and centering surfaces, if possible use methyl alcohol. Preferably use paper towels. Do not use solvents and other corrosive liquids on magnet to avoid damaging it; any dirt can be removed from the magnets by using gummed paper. Do not hack or put pressure on the magnet during its handling, it would cause them, damages because of their fragility.

11.2. Periodic preventive maintenance

Instructions relating to maintenance activities whose implementation do not require specific skills that can then be made by users of the pump, are given. These are programmed operations and inspections on issues considered important for technical, operational and staff safety purposes, based on *Bedu Pompen* experience and knowledge.

If the hydraulic pump is washed with pressure jet, prevent water entry into the motor terminal box.

	DANGER Do not throw water on the pump hot components: components can explode in case of sudden cooling generating projection of metallic material and under pressure hot liquid leakage hazardous to health. Do not stroke and pressure on the bearings, you would cause the formation of micro-cracks which can cause serious damages.
-----------------------------------------------------------------------------------	------------------------------------------------------------------------------------------------------------------------------------------------------------------------------------------------------------------------------------------------------------------------------------------------------------------------------------------------

N.	<u>Check description / action: implementation rules</u>	Warnings and protective measures be taken to perform the maintenance properly and safely	Time intervals
1	Ball bearing frame	Fill up the oil until the middle of the level indicator plug	Weekly. Replace oil every 5,000 hours.
2	Internal bearings	Check the status of bushings, sleeve bearings and thrust bearings, replace them if worn	After 2500 hours, check any premature wear, then every 5,000hours or every year.
3	Wear rings	Check the status of the wear ring, consult the table of tolerances	After 2500 hours, check for premature wear, then every 5000 hours or every year.
4	Motor bearings	Unless other specifications, motor bearings are greased for life, so there is not a maintenance schedule, anyway it is recommended to check the condition of the bearings and replace them when worn	

RECOMMENDED OILS TABLE: for ambient temperatures exceeding 15 ° c, by classification ISO VG 68)



CAUTION

BP HPL 68
 CHEVRON EP industrial oil 68
 Texaco Rando Oil HDC 68
 TOTAL Azolla 68
 Shell Tellus 68
 Mobil DTE Heavy Medium ISO 68
 STATOIL HYDRAWAY HV 68
 Esso Teresso 68 / AGIP OSO 68

In **Appendix A** is a list of periodic maintenance and inspections to be completed each time you perform such operations.

11.2.1. Emptying of the fluid contained in the pump

Before disassembling, you must empty the liquid from the pump according to the following steps:

- Close the valves present in the inlet and outlet pipes, and in the cooling pipe;
- Unscrew the drain plug;
- When emptied, screw the drain plug again.

If hazardous to health liquids are pumped, wear suitable personal protective equipment before coming in contact with the liquid.

11.2.2. Emptying the oil contained in the pump

If the pump is designed with oil lubricated bearing frame (bare shaft versions):

- remove the oil drain plug;
- drain the oil and collect it without dispersing into the environment;
- replace the drain plug .

If there are fluids hazardous to health, wear personal protective equipment suitable before coming in contact with the liquid.

11.3. Extraordinary maintenance

The extraordinary maintenance operations concern the activities that are beyond those typically programmable and executable; they require precise technical expertise by qualified personnel, and then is recommended to contact *Bedu Pompen*.

DANGER



If it becomes necessary to disassemble the pump, you must remember that the liquid should be collected and disposed in accordance to existing environmental laws. If the pump should be sent to *Bedu Pompen* it must be drained, cleaned and must not contain any traces of pumped liquid.

12. REPAIR AND PARTS REPLACEMENT

The pump must always be kept in optimum operation conditions.

Most of the spare parts have clear and comprehensive references for their identification. It is important that the pump components, in the case of repair, are replaced by original ones: to order original spare parts, contact *Bedu Pompen* referring to the model of the pump, serial number, description of the component and the quantity needed.

When you see elements with rust, cracks, etc, you must perform all replacements/repairs necessary to re-establish the safe operating conditions of the pump. In any case it is advisable to ask *Bedu Pompen* opinion before any intervention.

Periodic maintenance specified in paragraph "PERIODIC AND EXTRAORDINARY MAINTENANCE" must be followed.

13. PERIODIC AND EXTRAORDINARY MAINTENANCE"

13.1. Pump disassembling

If the pump has pumped hot liquids, make sure that it has been cooled before disassembly. The pump may have pumped liquid hazardous to health is therefore necessary to wear personal protective equipment.

Before to proceed with disassembling, follow carefully the decommissioning instructions, at paragraph 20.2.

The activities of disassembly and maintenance of the pump should be conducted in full compliance with current health and safety regulations. Some spare parts may have potential health risk to the operators:

CAUTION

Bedu Pompen disclaims any liability for damage to property and people and will invalidate the warranty if you install non original components.

MAGNETIC

The pumps built by *Bedu Pompen* contain extremely strong magnets. The use of tools and work surfaces not ferromagnetic is highly recommended. The department in which you perform maintenance must be clean and free of iron particles that may be attracted by magnets.

Pay attention to the strong magnetic attraction when you work in proximity of the internal or external magnets. Tools can be strongly attracted by magnets, or slip from the hands causing damages to fingers and hands, moreover, the magnets may be strongly attracted by ferromagnetic devices present in the area.

In case of need, pump internal parts can be pull out from the hydraulic end without disconnecting plant piping.

If it is the bare shaft version, with coupling and spacer, pump internal parts can even be removed without taking apart the electric motor.

Having in mind instructions in paragraph 18.2 "Periodic preventive maintenance", proceed to dismantle as illustrated below.

13.2. Pump disassembling

For long couple units, with elastic coupling with spacer, it is possible to remove the internal assembly without disassembly the electric motor.

Considering the instruction for "PERIODIC AND EXTRAORDINARY MAINTENANCE ", proceed as explained below:

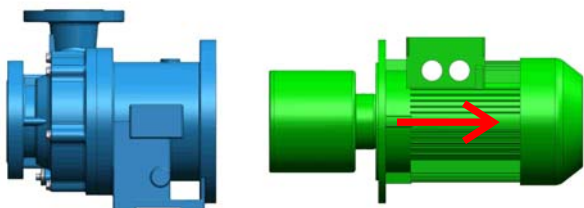

1) Unscrew motor screw, then, pull out the electric motor, with external magnet, from pump bracket.

Place the pump on a firm base.

2) Remove pump casing screws

3) Extract the pump casing assembly

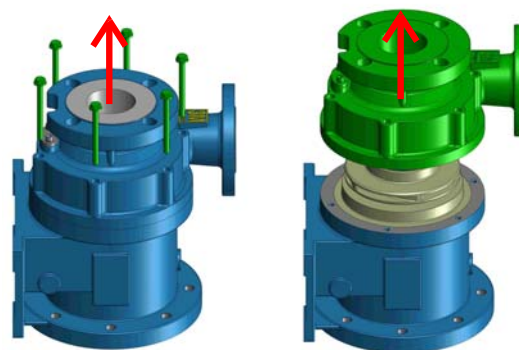

4) Check thrust bearing and shaft support. Replace it in case of wear or damage.

5) Remove pump casing O-RING.

It is recommended to replace the casing O-RING at every reassembly.

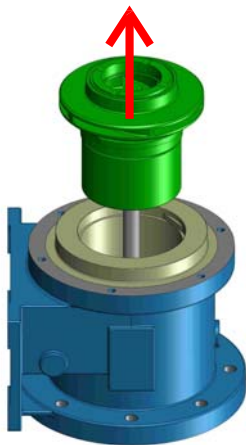
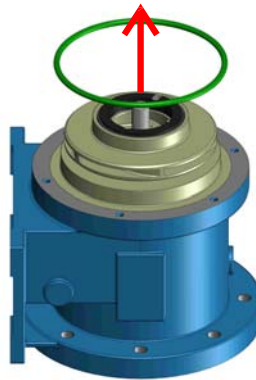

6) Extract the internal cartridge (RWP) from the pump.

7) Using an extractor, remove the impeller.

Check status of thrust bearings, replace it in case of damage or wear

For PP and PVDF version, the thrust bearings are kept in place by elastomeric glows. Replace the glows at every reassembly.

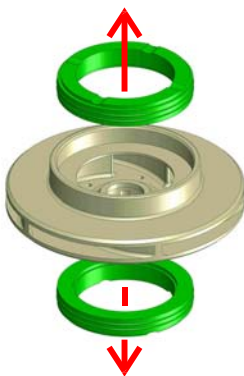

8) Check impeller thrust bearings; replace it in case of damage or wear.

9) Check status of rear thrust bearing; replace it in case of damage or wear.

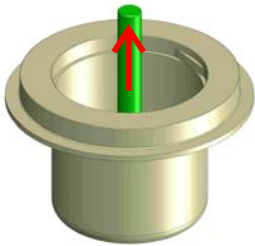

10) Check shaft status, replace it in case of damage or wear



11) Check internal magnet status, inspect the external surfaces, and replace it in case of damage or wear.
Check the bearings; replace it in case of damage or wear.

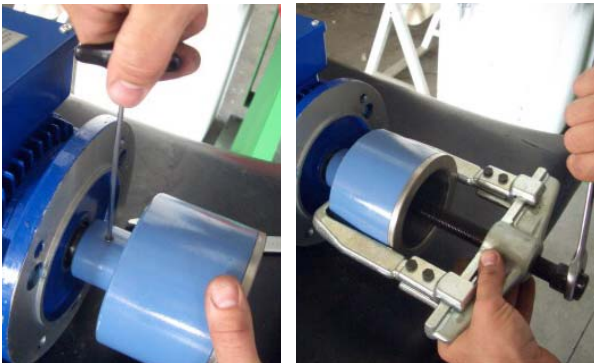

12) To remove the external magnet, unscrew the hub setscrew, then, using an extractor, pull out the magnet.

13) To recondition the bearing frame it is necessary:

remove the ball bearing covers (1) on both sides;
remove the seals (2) and replace them;
replace the gaskets (3) (recommended every time);
replace the ball bearings (4) if a failure occurred or if worn.

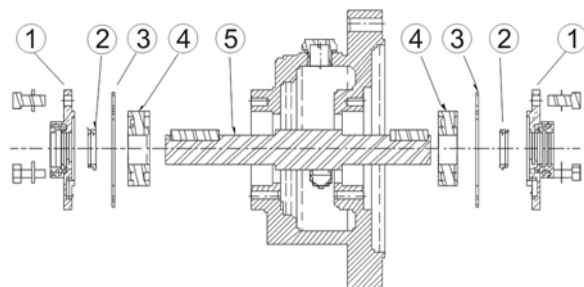

You can now replace all worn or damaged parts.

13.3. Pump reassembling

To reassemble the pump, follow maintenance procedure in reverse order. Clean each component before assembly; make sure that all parts are free from dirt, metallic particles, etc.

14. DECOMMISSIONING, DISMANTLING AND DISPOSAL OF MATERIALS

14.1. Decommissioning

For an eventual long time decommissioning, it is advisable to apply some simple precautions to preserve correctly the pump.

Make the pump run with clean water (or other suitable solvent compatible with the materials of the pump) for several minutes, in order to avoid the risk of liquid precipitation or deposits. Disconnect from the electric power / liquid supply and place it in a protected site.

During the commissioning after a long period of storing, carefully follow all recommendations for commissioning described in this manual.

CAUTION



A good storing procedure will guarantee against unpleasant incidents during the restarting of the pump. *Bedu Pompen* disclaims any responsibility for machines stored incorrectly. If you intend to stop using this pump it is recommended to make it inoperative.

14.2. Demolition and dismantling

The user must comply with the legislation on environmental conservation and will have to deal with the disposal and elimination of materials and harmful substances of the pump components. It is recommended to destroy the identification plates of the pump and any other document.

15. EXPLODED VIEW PART LIST

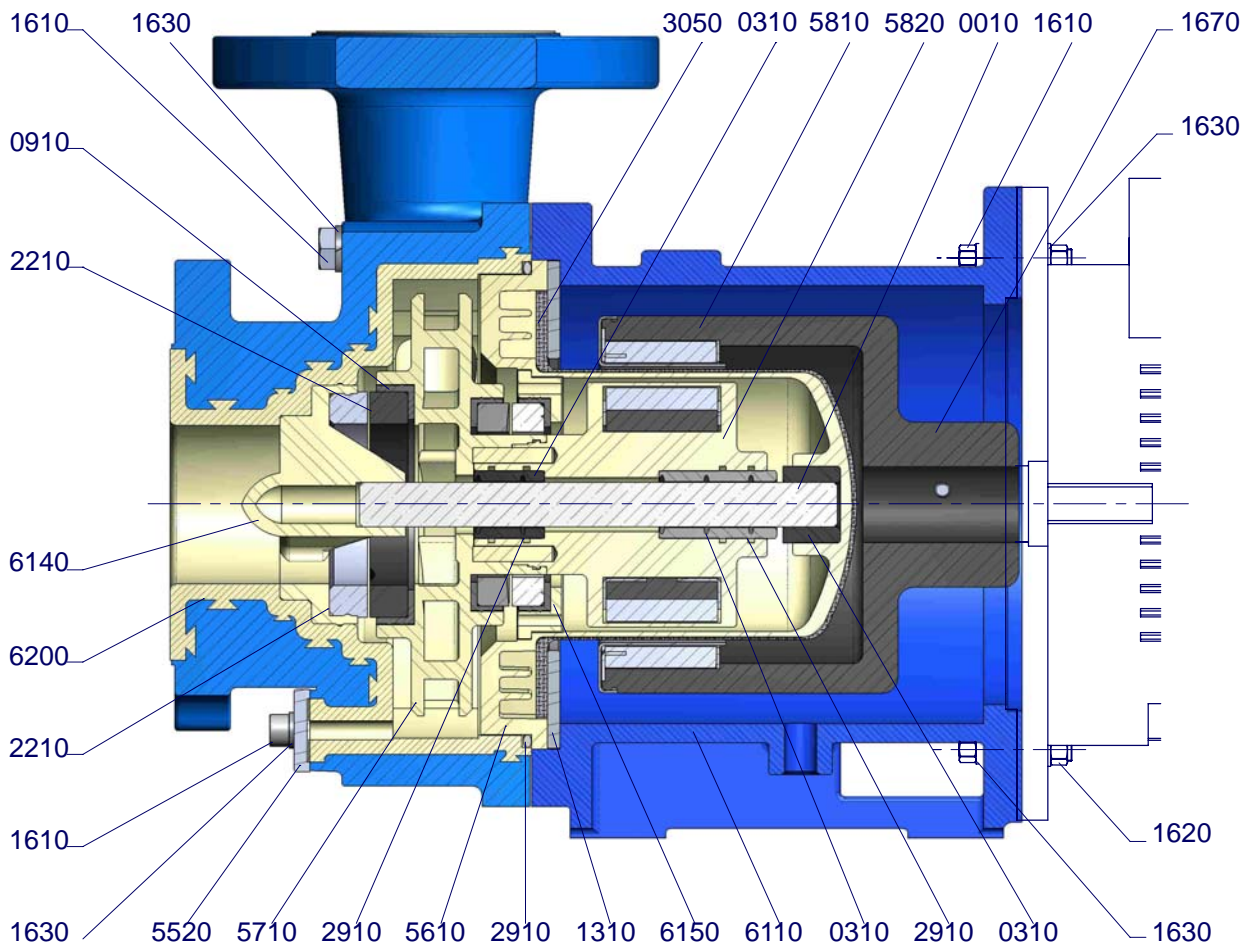

N°	Descrizione	Description
0010	Albero	Shaft
0310	Boccola	Bushing
0910	Cuffia	Glove
1310	Flangia di Serraggio del Corpo Posteriore	Rear Casing Reinforced Ring
1610	Vite	Screw
1620	Dado	Nut
1630	Rondella	Washer
1670	Grano	Exagon Socket Set Screws
2210	Ralla	Thrust Bearing
2910	O-ring	O-ring
3050	Corazza del Corpo Posteriore	Rear Casing Cover
5520	Coperchio Scarico	Discharge Cover
5610	Corpo Posteriore	Rear Casing
5710	Girante	Impeller
5810	Magnete Esterno	External Magnet
5820	Magnete interno	Internal Magnet
6110	Supporto Motore	Bracket
6140	Supporto Anteriore Albero	Front Shaft Support
6150	Supporto Reggispinta	Thrust Bearing Support
6200	Corpo Pompa Lined	Lined Pump Casing

DATE	DESCRIPTION OF OPERATION (report the numbers associated with intervention and any operations carried out in addition)	OPERATOR SIGNATURE

Notes

A series of 20 horizontal dotted lines for writing notes.

Notes

A series of 20 horizontal dotted lines for writing notes.



EC - Declaration of Conformity

Manufacturer Details

Tradename

Bedu Pompen BV

Address

Poort van Midden Gelderland Rood 10, 6666 LT, Heteren, Netherlands

Product Details

Product Name

Centrifugal pumps

Model (+series) Name

C MAG-PL series

Applicable Standards Details

Directives

2006/42/EC (Machinery Directive)
2014/35/EU (Low Voltage Directive)
2014/30/EU (Electromagnetic compatibility)

Standards

EN-ISO 12100:2010
EN-IEC 60204-1:2006
EN 809+A1/C1

Additional information

No further details.

Declaration

We hereby declare under our sole responsibility that the product(s) mentioned above to which this declaration relates complies with the above mentioned standards and Directives.

Business Unit Manager: Issued Date:

01/10 2014

BEDU Pompen BV

Poort van Midden Gelderland Rood 10
6666 LT Heteren

Tel : +31 (0)88 - 4802 900

Fax : +31 (0)88 - 4802 901

E-mail : info@bedu.nl

Website : www.bedu.eu

Marco Breunissen

Signature of representative(s)

The logo consists of the word "BEDU" in a large, bold, white sans-serif font, with "POMPEN" in a smaller, white sans-serif font below it. The text is centered within a dark teal square, which is itself centered within a white square border.

BEDU
POMPEN

made for your process

- Expert advice
- A customer-oriented organization that adapts to the requirements and wishes of your organization
- Innovative and customized solutions
- Breakdownservice, 24 hours a day, 7 days a week
- Technical service with extensive test facilities, working from our own workplace or at your location
- A fast and appropriate solution for all your issues
- Wide range of liquid pumps
- Repair, maintenance and revision

BEDU POMPEN B.V.
Poort van Midden Gelderland Rood 10
6666 LT HETEREN
Nederland
Telefoon +31 (0)88 4802 900
E-mail sales@bedu.eu

WWW.BEDU.NL

BEDU BELGIUM B.V.B.A.
Industriepark-West 75
9100 SINT-NIKLAAS
België
Telefoon +32 (0)3 80 87 980
E-mail sales@bedu.eu

WWW.BEDU.BE

