



50Hz

water solutions

**Grey** SERIES

**APG series**

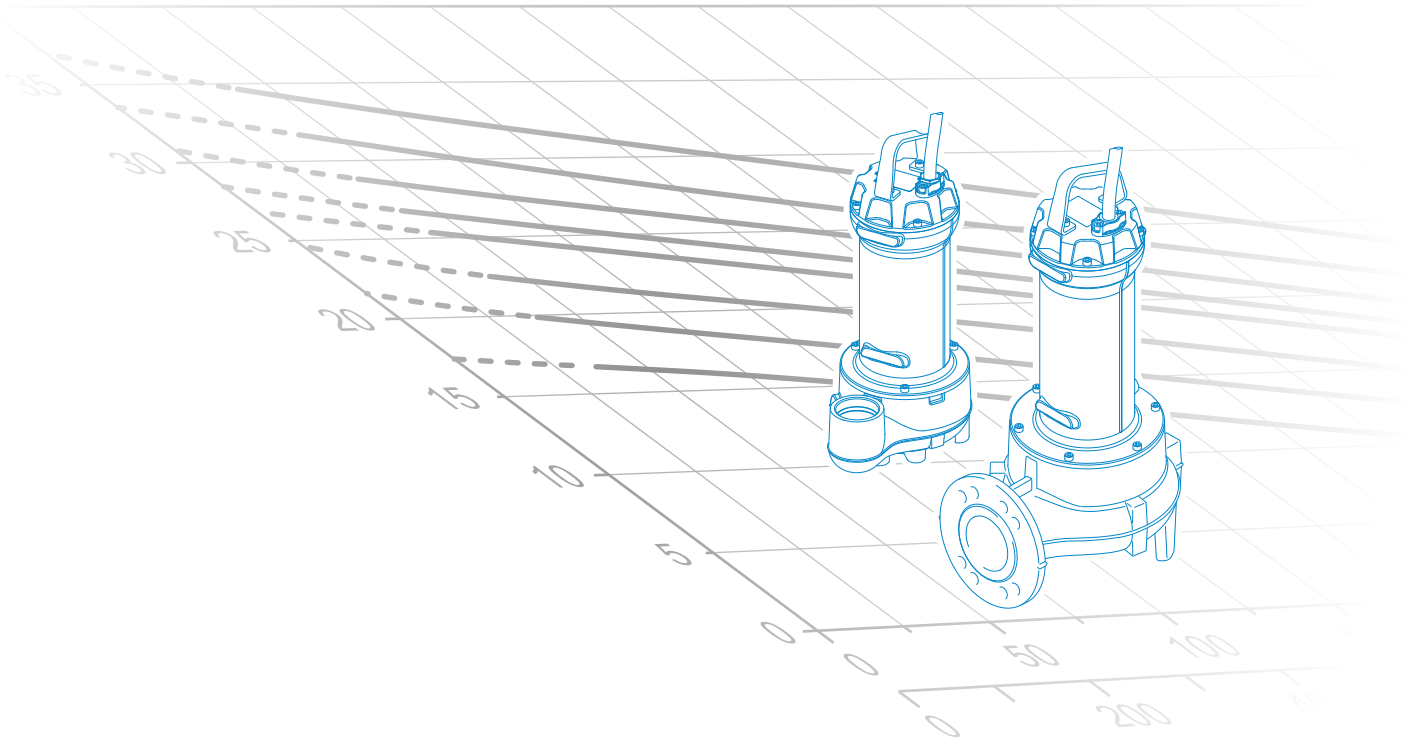

D A T A   B O O K L E T



## Grey Series

### General characteristics

#### Motor

- Electrical submersible pumps in GJL-250 cast iron
- Two silicon carbide (2SiC) mechanical seals in oil sump
- Ecological dry motor with thermal protection
- Sensor for detecting water in the mechanical seal oil sump
- Self lubricated ball bearings

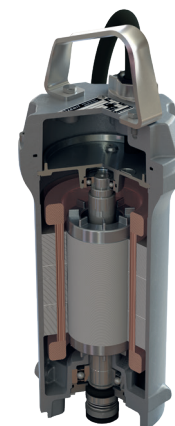

### Hydraulic families

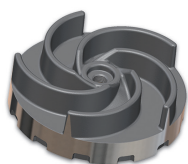

#### DG (Draga)

page 7

- Set-back vortex impeller
- Used with unstrained soiled biological wastewaters and sewage and for civil lifting applications. It is thus ideal for wastewater treatment plants, sewer systems, livestock farms, industry and agriculture.

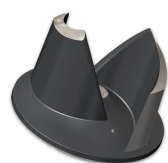

#### DR (Dreno)

page 18

- Multi-channel open impeller
- Designed for mainly professional and industrial use such as wastewater treatment plants, sewage systems and livestock farms, it is particularly suitable for the treatment of liquids containing suspended solids or filaments, and low or medium density activated sludges.

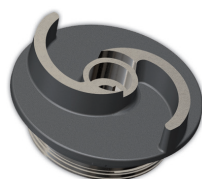

#### GR (Grinder)

page 33

- Impeller with grinder system
- Designed for professional and industrial use, it is suitable for the treatment of liquids containing suspended solids or fibres, and low or medium density activated sludges.

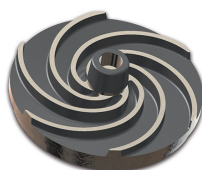

#### AP (Alta Prevalenza)

page 41

- High head impeller
- Suitable for clear wastewater, rainwater and seepage. The considerable manometric head guarantees excellent results for the creation of water features and decorative fountains; suitable for use in agriculture, irrigation and the fish processing sector.

## Operating ranges

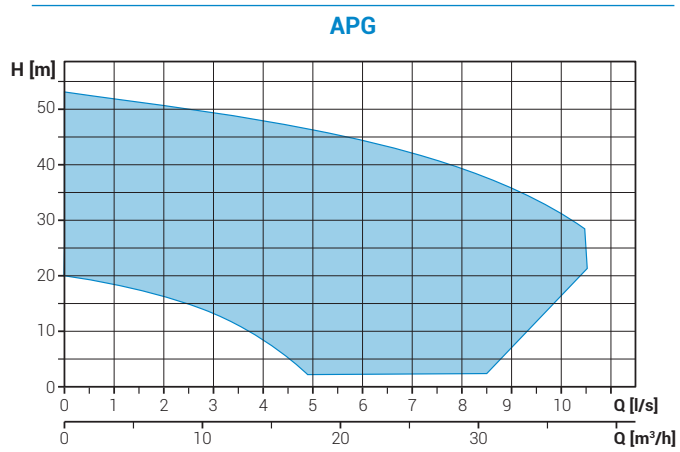
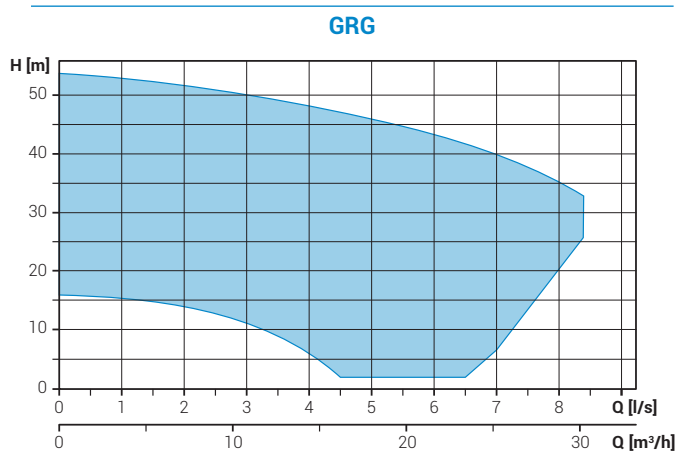
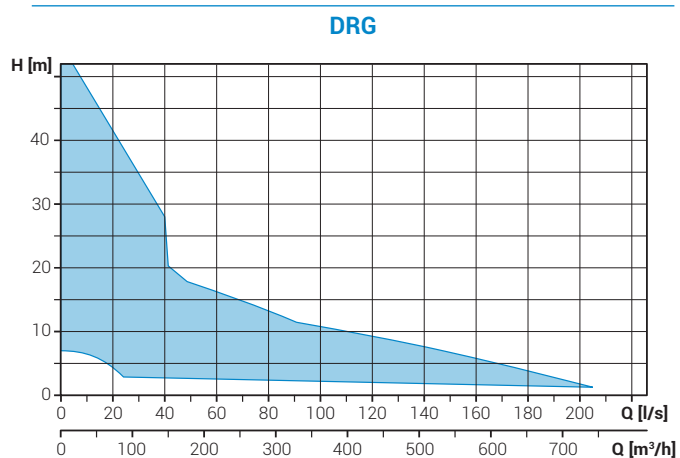
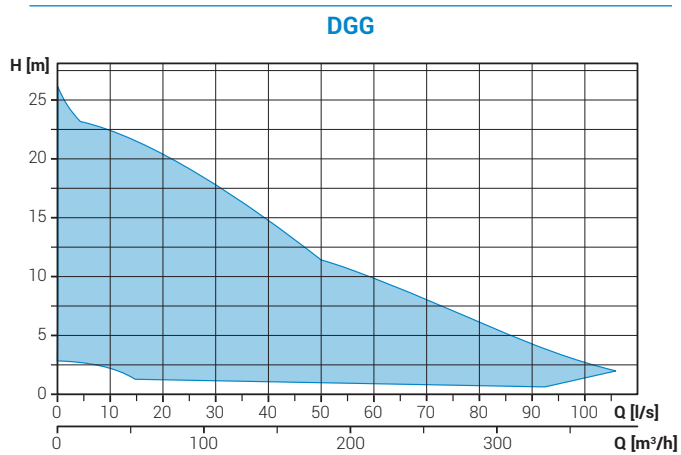

## Versions available

- Electrical variants

<b>NAE</b>	No electric accessories
<b>TS</b>	Thermal protection, sensor for detecting water in the mechanical seal oil sump

- Cooling system

<b>N</b>	No cooling and/or seal flushing system
----------	--

- Set of mechanical seals

<b>2SiC</b>	2 mechanical seals in silicon carbide
-------------	---------------------------------------

## Key to product code

DGG 300/2/G65V A0ET5

① ② ③ (A) (B) (C) ④ ⑤ ⑥ ⑦ ⑧ ⑨

- |                                |                                  |
|--------------------------------|----------------------------------|
| ① Family                       | ⑤ Hydraulic model                |
| ② Series                       | ⑥ Version number                 |
| ③ Power (HPx100) / motor poles | ⑦ Motor size                     |
| ④ Delivery rate                | ⑧ Motor phases                   |
| (A) TYPE (GAS thread/Flanged)  | M = Single-phase                 |
| (B) DIAMETER (mm)              | T = Three-phase                  |
| (C) POSITION                   | ⑨ Power supply voltage frequency |
| V = vertical                   | 5 = 50Hz                         |
| H = horizontal                 | 6 = 60Hz                         |

## Installations

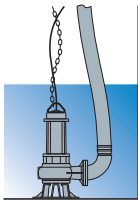

### Free installation

The electric pump, standing on its feet or base, is connected to the delivery flexible pipe using a joint fixed to the discharge. This installation allows to move easily the electrical pump

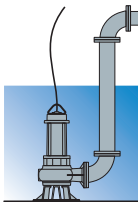

### Fixed installation

The electric pump, standing on its feet or base, is connected to the delivery pipe, which is screwed to the discharge if threaded, or fixed to a bend if the port is flanged. The pump-hose connection may be threaded or flanged, depending on the pump fitting.

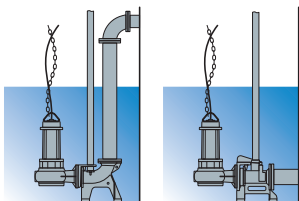

### Installation with base coupling foot

Available for electric pumps with threaded discharge. The pump unit is supported by a special device fitted to the delivery pipe. This device can be installed at any time without having to empty the tank. It simplifies any maintenance work on the pump, which can be lifted out and resubmerged with great ease. It is recommended in particular for installations of small size, and does not require the pump to be resting on the bottom of the tank.

## High head impeller

### Operating ranges

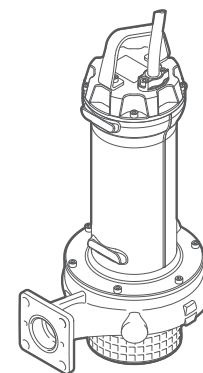
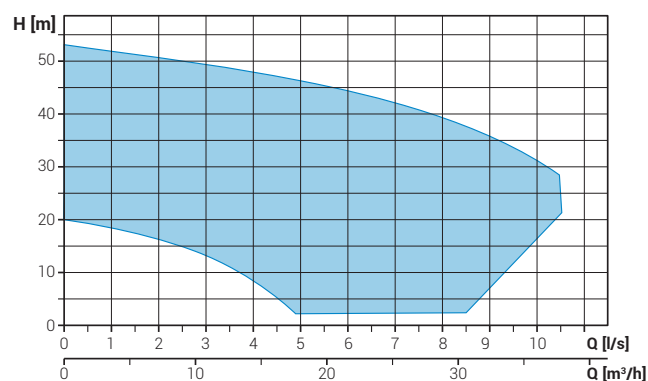

### Range characteristics

Motor power	1.8 ÷ 7.5 kW
Poles	2
Insulation class	H
Degree of protection	IP68
Discharge	GAS 1½ - 2" DN32 horizontal
Free passage	max 10 mm
Max flow rate	10.5 l/s
Max head	53.0 m

### Motor

Ecological dry motor with thermal protections.

### Cable

S1RN8-F electric cable. Standard version 10 m cable length.

### Mechanical seals

Two silicon carbide (SiC) mechanical seals in oil sump.

### Applications

The considerable manometric head guarantees excellent results for the creation of water features and decorative fountains; suitable for use in agriculture, irrigation and the fish processing sector.

### Installations

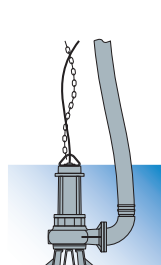

Free

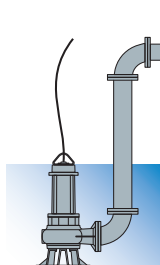

Fixed

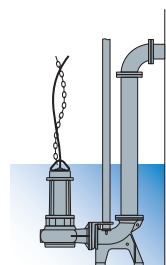

with base coupling foot

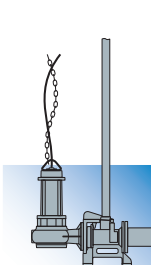

### Versions

Electrical variants	NAE, TS
Cooling system	N
Mechanical seals	2SiC

### Operating specifications

Max operating temperature	40 °C
PH of treated fluid	6 ÷ 14
Viscosity of treated fluid	1 mm²/s
Maximum immersion depth	20 m
Density of treated fluid	1 Kg/dm³
Acoustic pressure max	<70dB
Max starts per hour	30

### Construction materials

Case	Cast iron EN-GJL 250
Hydraulic parts	Cast iron EN-GJL 250
Impeller	Cast iron EN-GJL 250
Nuts and bolts	Stainless steel - Class A2-70
Standard gasket	Rubber - NBR
Shaft	Stainless steel - AISI 431
Strainer	Stainless steel - AISI 304
Paint type	Ecological bicomponent epoxy (~ 200 µm)

# APG 250/2/G40H

## Performances

	l/s	0	1	2	3	4	5	6	7
	l/min	0	60	120	180	240	300	360	420
	m <sup>3</sup> /h	0	3.6	7.2	10.8	14.4	18	21.6	25.2
① APG 250/2/G40H A0AT5		26.0	25.7	24.6	23.3	21.6	19.2	16.2	12.3

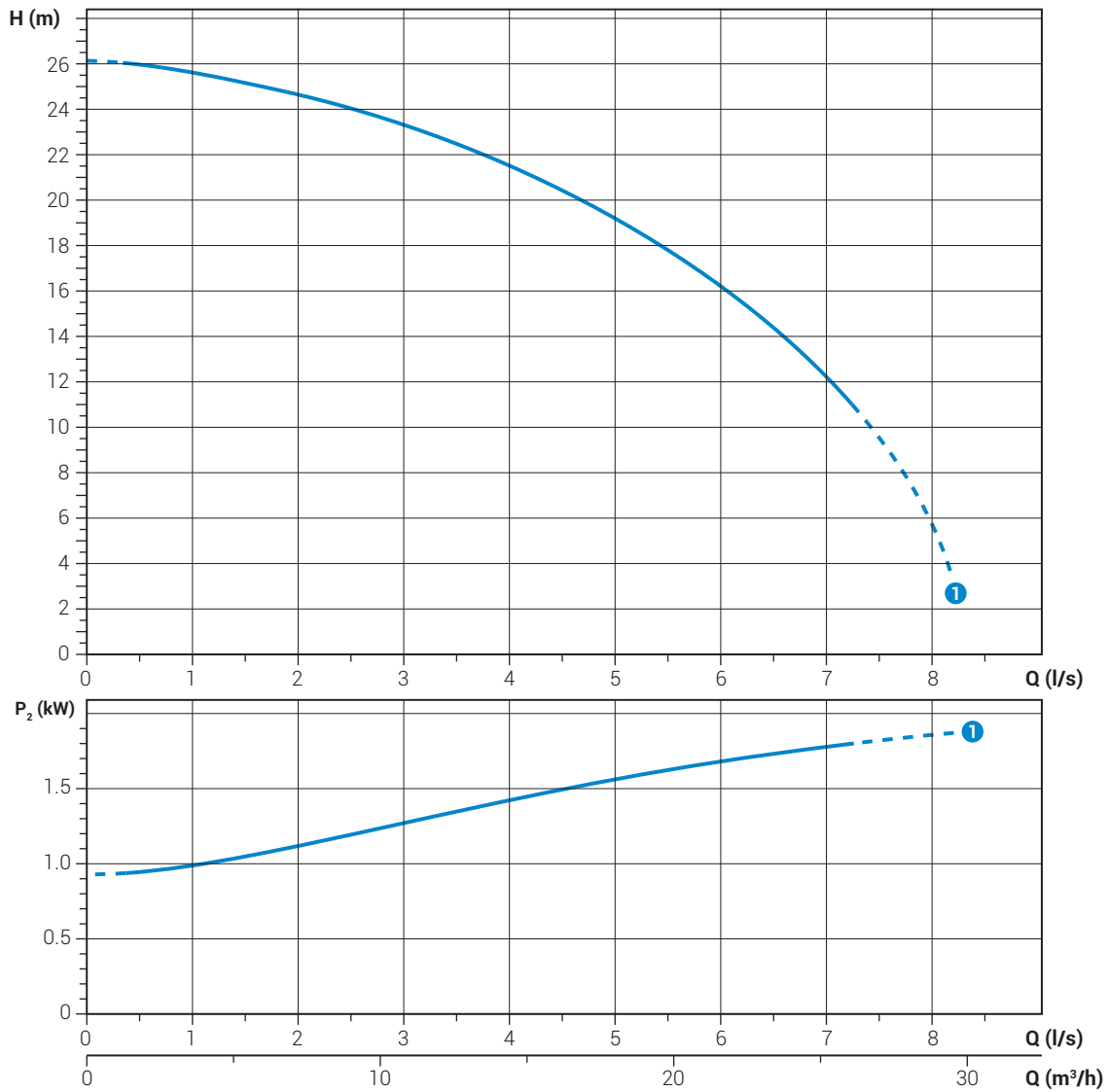

Characteristic curves according to UNI EN ISO 9906

## Technical data

	V	Phases	P1 (kW)	P2 (kW)	A	Rpm	Start	Cable	Ø	Free passage
① APG 250/2/G40H A0AT5	400	3	2.19	1.8	3.7	2900	Dir	4G1	DN32-G 1½"	10 mm

# APG 300 ÷ 1000/2/G50H

## Performances

	I/s	0	1	2	3	4	5	6	7	8	9	10
	l/min	0	60	120	180	240	300	360	420	480	540	600
	m <sup>3</sup> /h	0	3.6	7.2	10.8	14.4	18	21.6	25.2	28.8	32.4	36
① APG 300/2/G50H COET5		29.2	28.2	27.0	25.6	24.1	22.5	20.4	17.6			
② APG 400/2/G50H DOET5		32.2	31.4	29.9	28.5	27.2	25.9	24.4				
③ APG 550/2/G50H DOFT5		38.6	37.6	36.1	34.5	32.9	31.3	29.6	27.7	25.4		
④ APG 750/2/G50H A0FT5		45.8	44.5	43.5	42.2	40.7	38.9	36.8	34.5	31.8	28.6	24.2
⑤ APG 1000/2/G50H A0FT5		53.0	51.8	50.7	49.4	48.0	46.3	44.3	42.0	39.2	35.8	31.2

Characteristic curves according to UNI EN ISO 9906

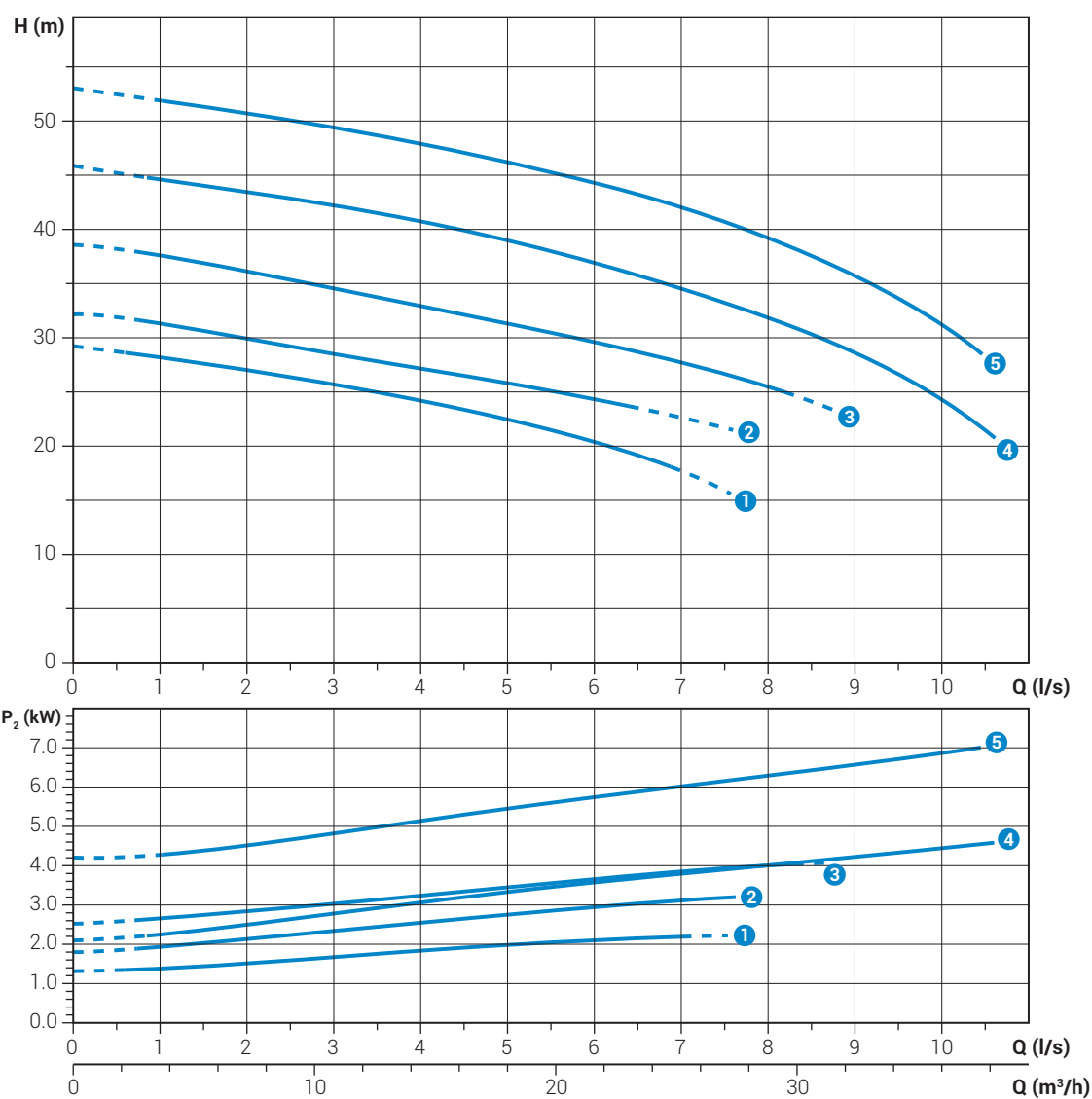

## Technical data

	V	Phases	P1 (kW)	P2 (kW)	A	Rpm	Start	Cable	Ø	Free passage
① APG 300/2/G50H COET5	400	3	2.76	2.2	4.62	2900	Dir	4G1.5+3x1	DN32 - G2"	8 mm
② APG 400/2/G50H DOET5	400	3	3.68	3.0	6.36	2900	Dir	4G1.5+3x1	DN32 - G2"	8 mm
③ APG 550/2/G50H DOFT5	400	3	4.66	4.0	7.73	2900	Dir	4G1.5+3x1	DN32 - G2"	8 mm
④ APG 750/2/G50H A0FT5	400	3	6.32	5.5	10.8	2900	Dir	4G1.5+3x1	DN32 - G2"	10 mm
⑤ APG 1000/2/G50H A0FT5	400	3	8.51	7.5	13.7	2900	Dir	4G1.5+3x1	DN32 - G2"	10 mm

# APG

## Overall dimensions and weights

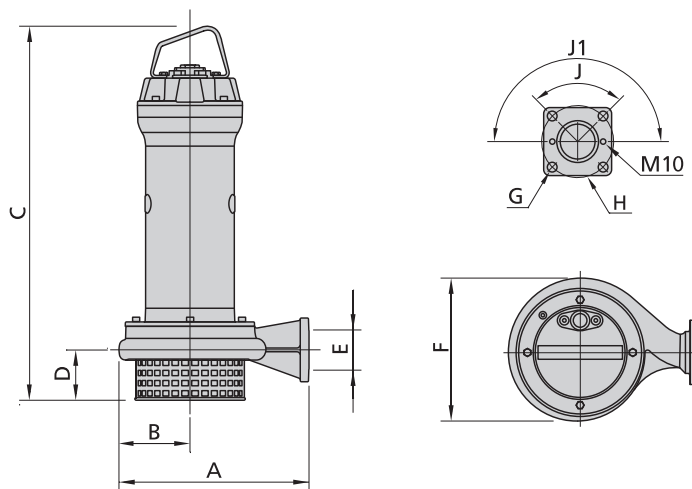

	A	B	C	D	E	F	G	H	J°	J1°	kg
APG 250/2/G40H A0AT5	267	107	523	78	GAS 1½" - DN32	215	14	90	90	-	32
APG 300/2/G50H C0ET5	305	110	550	79	GAS 2" - DN32	225	18	125	45	90	58.6
APG 400/2/G50H D0ET5	352	132	613	76	GAS 2" - DN32	263	18	125	45	90	60.6
APG 550/2/G50H D0FT5	352	132	670	76	GAS 2" - DN32	263	18	125	45	90	57.0
APG 750/2/G50H A0FT5	352	128	669	76	GAS 2" - DN32	263	18	125	45	90	59.7
APG 1000/2/G50H A0FT5	352	128	744	76	GAS 2" - DN32	263	18	125	45	90	68.7

Dimensions in mm

## Packaging dimension



	X	Y	Z
APG 250/2/G40H A0AT5	310	580	310
APG 300/2/G50H C0ET5	445	725	425
APG 400/2/G50H D0ET5	445	725	425
APG 550/2/G50H D0FT5	445	725	425
APG 750/2/G50H A0FT5	445	725	425
APG 1000/2/G50H A0FT5	535	915	560

Dimensions in mm



The logo for BEDU POMPEN is centered in a white square. It features the word "BEDU" in a large, bold, white sans-serif font. Below it, the word "POMPEN" is written in a smaller, white sans-serif font, flanked by two horizontal lines on each side.

**BEDU**  
POMPEN

## made for your process

- Expert advice
- A customer-oriented organization that adapts to the requirements and wishes of your organization
- Innovative and customized solutions
- Breakdownservice, 24 hours a day, 7 days a week
- Technical service with extensive test facilities, working from our own workplace or at your location
- A fast and appropriate solution for all your issues
- Wide range of liquid pumps
- Repair, maintenance and revision

BEDU POMPEN B.V.  
Poort van Midden Gelderland Rood 10  
6666 LT HETEREN  
Nederland  
Telefoon +31 (0)88 4802 900  
E-mail [sales@bedu.eu](mailto:sales@bedu.eu)

[WWW.BEDU.NL](http://WWW.BEDU.NL)

BEDU BELGIUM B.V.B.A.  
Industriepark-West 75  
9100 SINT-NIKLAAS  
België  
Telefoon +32 (0)3 80 87 980  
E-mail [sales@bedu.eu](mailto:sales@bedu.eu)

[WWW.BEDU.BE](http://WWW.BEDU.BE)

