

**BEDU**  
≡ P O M P E N ≡

# Peristaltic pumps

MS0 / MS1 / MS2 / MS3



made for your process



# Simple Principle

The basic principle of the peristaltic pump traces back to human “peristalsis” a term referring to the alternating contraction and relaxation of muscles around a tube to force the contents through it. An elastomeric tube is squeezed along a length by rollers that push the fluid contained within. The tube’s restitution after squeezing produces a vacuum that draws fluid continuously into the tube. This creates a gentle pumping action that doesn’t cause any damage to the product. Contaminations are avoided because the fluid is contained within the tube (one contact part with product). The pump employs a rotor with rollers mounted on it that continually compress and occlude some portion of the tube. This action moves the fluid through the tube with a constant rate of displacement for each revolution of the rotor, enabling a precise measurement of the volume of fluid pumped through the tube.

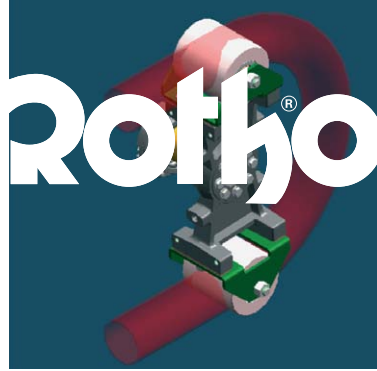

# The Rotho Pump

The “roller on bearings” design of the Rotho pump offers many advantages:

- It eliminates the requirement for adding a lubrication fluid inside the pump housing, because there is no friction on the surface of the tube therefore giving a longer tube life.
- **it requires smaller drives, so less power installed, compared to others peristaltic pumps, to get the same rpm and capacity.**
- They can transfer food products with no contamination hazards, as the pump housing is lubrication free.
- With no lubrication fluid required, hose replacement is greatly simplified and cheaper without having to drain and dispose of a messy and possibly contaminated oil or glycerine solution.



# Advantages

No seals

No valves

Self priming

Only tube to replace

Reverse flow by reversing motor

No contact between product and mechanical parts

Can run dry without damage

Able to pump products with solid parts inside

Suitable for CIP applications

# Uses

Transfer, feed, meter, filter of:

Fragile or sensitive fluids

Compound fluids

Abrasive and corrosive fluids

Non pollutable or pollutant fluids

# Fields of application



Ceramic



Chemical



Water and waste treatments



Food & beverage



Metallurgy



Pulppaper



Construction



Painting and pigment



Ink



Mining



Marine



Biogas

## Abrasive Products

The Rotho pump is excellent on abrasive slurries where it has had much more success than other pumps. The Rotho pump parts stay out of the product zone and the hose is the only one thing that is in contact with the product, this keeping abrasive wear to a minimum.

Products that crystallize are also well pumped by the Rotho pump.

There are no valves or glands so the eventual build up of crystals could not clog the pump.



## Corrosive Products

With corrosive fluids the hose selection is of paramount importance to the longevity of the pump. With the correct hose selection and no other contact mechanical parts in the product, this ensures a long pump life.



## Fluids With Solid Parts Or Sensitive Products

A problematic product for many pump types is fluids with solid particles such as waste water with gravel, pieces of wood, concrete or foods, where as the peristaltic pump due to free tube-passage can easily transfer it without any product or pump damage.

The Rotho pump is also a good choice for transferring shear-sensitive fluids or foamy products, the non emulsifying action minimises damage to the product or its consistency.



## Viscous Products

The Rotho pump gives a strong self-priming suction which can draw almost full vacuum, producing the pull necessary to draw viscous materials such as honey, grout, resins or waste sludge, which is almost impossible for many other pump types.



## Environmental Applications

There are two main environmental applications for the Rotho pump:

- Chemical metering
- Sludge transfer

### 1) Chemical metering:

The most common is for Sodium Hypochlorite, Sodium Bisulfite, Ferric Chloride and some polymers, as well as lime slurry and carbon slurry. Above all with sodium hypochlorite that emits off gas, the Rotho pump doesn't lose efficiency due to pockets of air, pumping together both liquid and gas

### 2) Sludge:

The Rotho pump can handle many different kinds of sludge depending upon the level of treatment in a plant. It can feed and transfer thickened sludge, waste activated sludge, return activated sludge and corrosive sludge.





# ROTHO tube

It is an elastomeric tube right for duty service and its selection depends by the product to pump, pressure, temperature; it is a multilayer hose with 2, 4 or 6 textile insert reinforcement depends by its dimension and pressure to win.



# The right hose for the right product

Hose Colour Identification	BLE	RED	GREEN	YELLOW	WHITE	ORANGE	BEIGE
Hose mark	<b>NN</b>	<b>NP</b>	<b>EP</b>	<b>RN</b>	<b>RF</b>	<b>HY</b>	<b>PH</b>
Composition	NATURAL ISOPRENE	Substrate for food products NATURAL ISOPRENE	Monomer Ethylene-Propylene EPDM	Nitril-Butadiene Substrate for foods NBR	Nitril-Butadiene For foods NBR	Polyethylene Chlorosulphonate HYPALON	PHARMED Thermoplastic Elastomer-base. Polypropylene
Technical features	Multilayer hose with textile insert reinforcement.	Multilayer hose with textile insert reinforcement.	Multilayer hose with textile insert reinforcement.	Multilayer hose with textile insert reinforcement.	Multilayer hose with textile insert reinforcement.	Multilayer hose with textile insert reinforcement.	Omogeneous tube, without textile insert.
TEMP. C°	-10 +85	-10 +75	-10 +95	-10 +75	-10 +75	-10 +85	-20 +135
PRESS. BAR	-0,9 +8 (15)	-0,9 +6(8)	-0,9 +8	-0,9 +6(8)	-0,9 +6(8)	-0,9 +8 (15)	-0,5 +1,5/2
Compatibility	Excellent behaviour for abrasive liquids and moderately aggressive liquids and fluids for high pressure.	Similar to NN type, suitable for foods products.	Suitable for chemical use and for relatively high pressure.	Suitable for oils, greases, hydrocarbons and various solvents.	Suitable for alimentary use, oils and fats.	Suitable for concentrated acids, alkaline liquids.	Suitable for alimentary and pharmaceutical products, (liquid).
Mechanical characteristics	Resistance/Duration HIGH	Resistance/Duration HIGH	Resistance/Duration MEDIUM	Resistance/Duration MEDIUM	Resistance/Duration HIGH	Resistance/Duration HIGH	Resistance/Duration HIGH
	Hose available for all models.	Hose available for all models.	Hose available for all models.	Hose available for all models.	Hose available for all models.	Hose available for all models.	Available for PSF serie only.
Alimentary classification		FDA-CFR 21 Parts 170 to 199 Item 177.2600			FDA 1777.2600 DM 21-3.73 IV B		FDA 177. 2600 NSF CRITERIA
For cleaning: C.I.P. and S.I.P. Suggest to remove the tube.		To sterilize whit water to 70° and solution of 5% volume surface-active agent, rinse with cold water.  Washing with steam to 120°, for max. 3 minutes.			To sterilize with water to 70° and solution of 5% volume surface-active agent, rinse with cold water.  Washing with steam to 120°, for max. 3 minutes.		To sterilize with hot water and neutral nonoil soaps. Rinse with distilled water.  Possibility to autoclave sterilization.

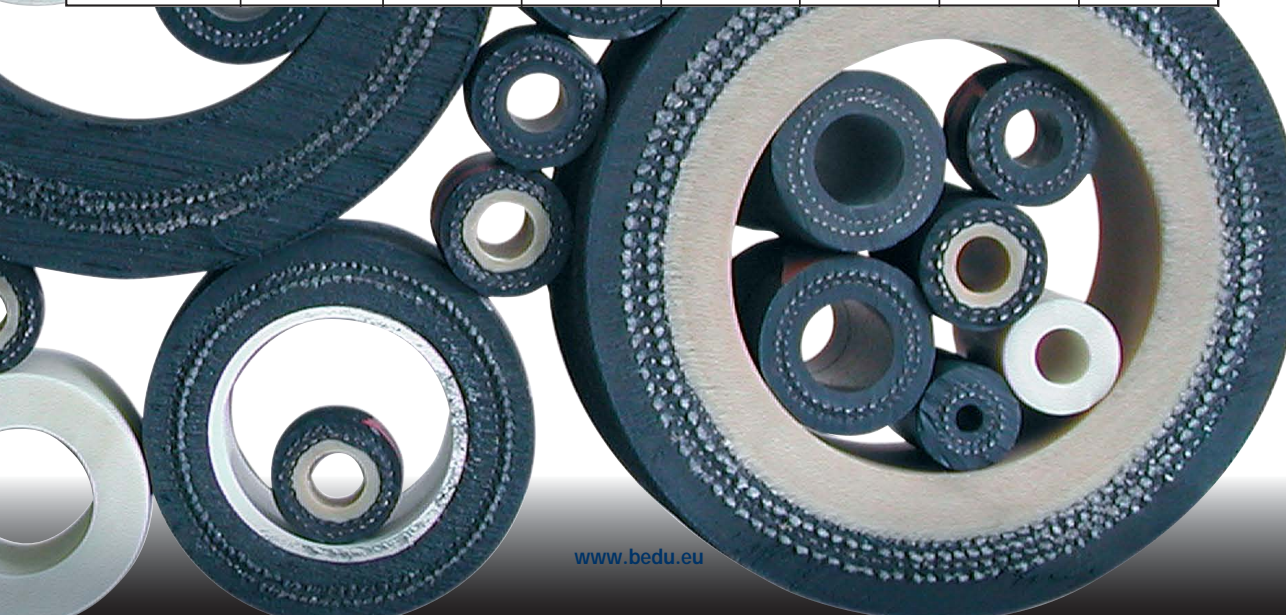



# Accessories and Optionals

## Connections



Flanges DIN; ANSI;  
DIN 11851 Threaded , Clamp, Tri-clamp, RJT, BSP threaded  
In: S.S. 316,  
PVC, PVDF, PTFE  
Polypropylene,  
Titanium

## Variable gear speed

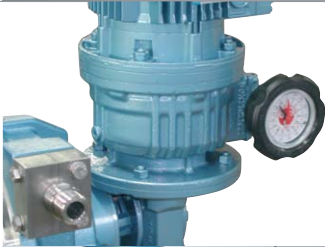

Ratio 1-5

## Frequency inverter



Possible arrangement  
for analogical signal 4-20mA, 0-10V.

## Pulse dampeners



The pulse dampeners are suggested in case of negative suction and pressure over 2 bar;  
they ensure a better pump working  
and a longer tube life.

Three types are available:

Membrane

Empty vessel

Flexible tube

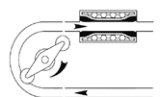
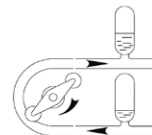
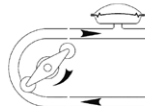



The models of MS and SDF Serie can be equipped of feeder to feed products with solid parts or sensitive parts.



**Feeder**

All Rotho pumps (optional for PSF Serie) are equipped of leak detector to provide early indication of hose failure. This is a float type sensor that is located at the lowest point of the pump housing.

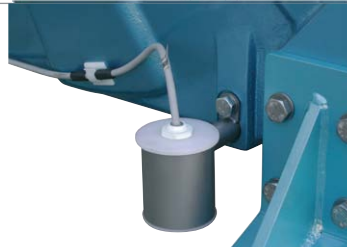

**Leak detector**

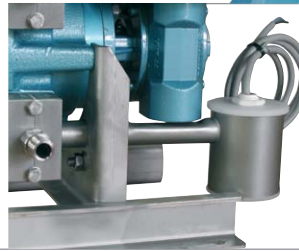

The “retractable” position of the roller is instrumental in increasing the lifetime of the tube element. When the pump is not in use for a certain period of time, the tube element can be separated from the roller from outside the pump by activating the rapid release mechanism of the retractable roller, quickly and safely without opening the pump casing.

This new positioning system is essential for all those pumps used for fully automated foodstuff handling that requires regular cleaning and sterilization of all components in contact with the product.

In this case, the retractable roller quickly releases the tube element, ensuring perfect CIP and SIP cleaning procedures whenever required.

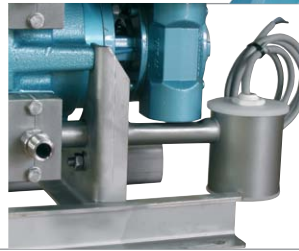

**Retractable roller**

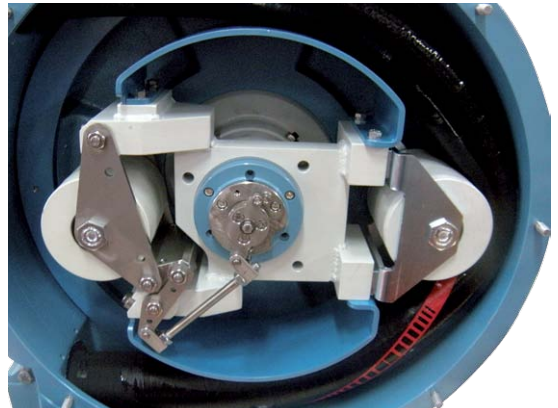

ATEX CERTIFICATION  
II GROUP – CAT. 2/3 – ZONE 1-2



## PSF serie

Capacity/h from 1lt up to 3.100 lt  
Pressure up to 8-15 bar  
Tubes diameter 5; 10; 16; 26 mm

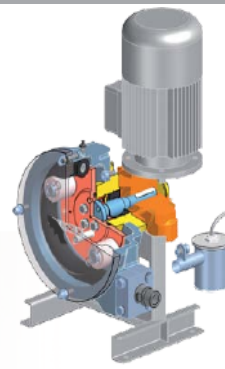

## MS serie

Capacity/h from 1.000 lt up to 18.000 lt  
Pressure up to 8-15 bar  
Tubes diameter 34; 40; 55; 68 mm

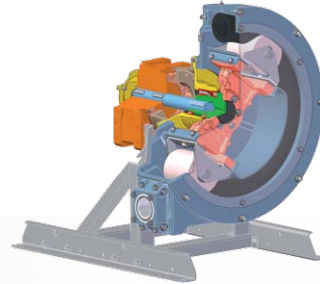

## SDF serie

Capacity/h from 10.000lt up to 70.000 lt  
Pressure up to 8-15 bar  
Tubes diameter 76; 90 mm

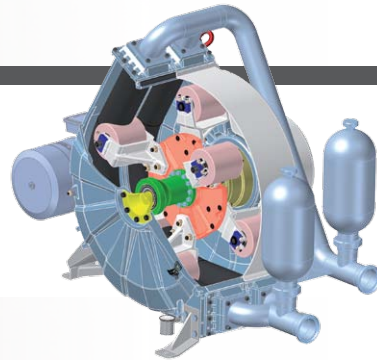

## SDR serie

Capacity/h from 80.000lt up to 180.000 lt  
Pressure up to 8-15 bar  
Tubes diameter 114; 127 mm



# MS0

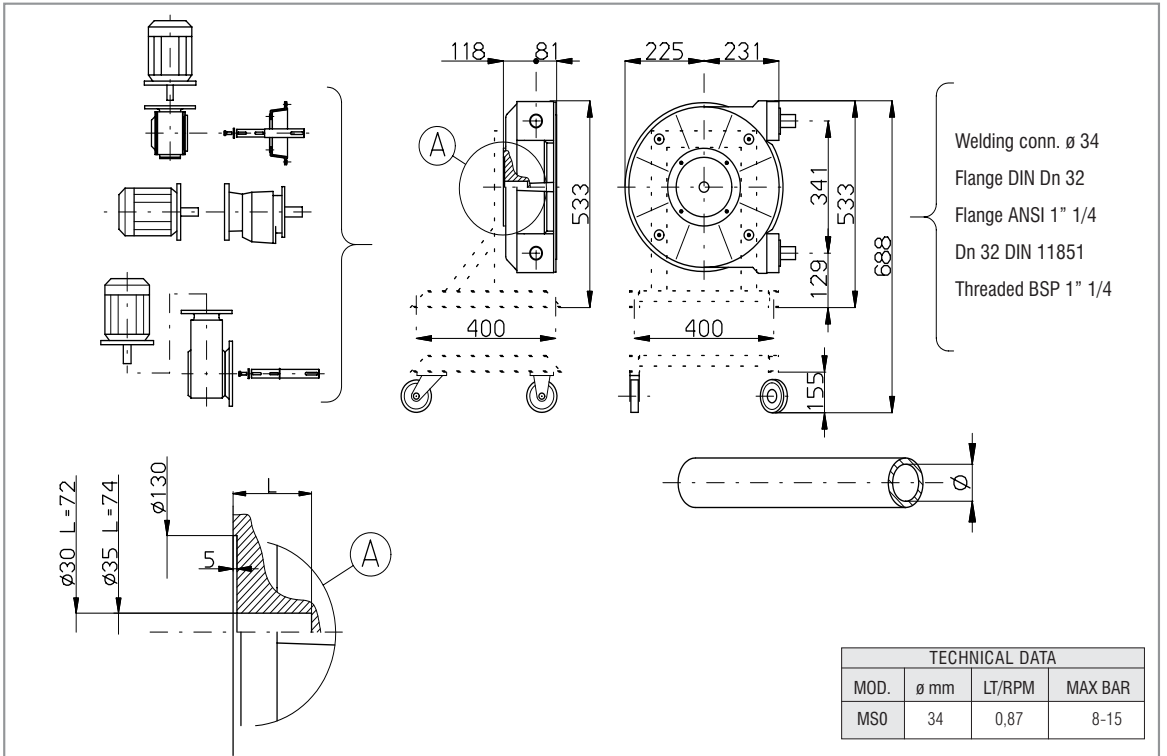

0-4 bar				
RPM	Lt/h	BAR		Kw
		std	max	
14	687	2	4	0,75
18	893	2	4	0,75
24	1201	2	4	0,75
28	1406	2	4	0,75
36	1817	2	4	1,5
47	2381	2	4	1,5
57	2894	2	4	1,5
71	3613	2	4	1,5
95	4845	2	4	2,2

4-8 bar				
RPM	Lt/h	BAR		Kw
		std	max	
14	673	4	8	0,75
15	723	4	8	0,75
17	824	4	8	0,75
19	924	4	8	0,75
21	1025	4	8	0,75
27	1326	4	8	0,75
30	1477	4	8	1,5
31	1528	4	8	1,5
35	1729	4	8	1,5
39	1930	4	8	1,5
44	2181	4	8	1,5
48	2382	4	8	1,5
57	2835	4	8	1,5
63	3137	4	6	1,5
71	3644	2	6	1,5
78	4004	2	6	2,2
91	4671	2	6	2,2

8-12 bar				
RPM	Lt/h	BAR		Kw
		std	max	
14	520	8	12	0,75
15	566	8	12	0,75
17	659	8	12	0,75
19	751	8	12	1,5
21	843	8	12	1,5
27	1120	8	12	1,5
30	1258	8	12	1,5
31	1304	8	12	1,5
35	1489	8	12	1,5
39	1673	8	12	1,5
44	1904	8	12	2,2
48	2088	8	10	2,2
57	2503	8	10	2,2
63	2780	8	8	2,2
71	2992	8	8	2,2
78	3315	8	6	2,2
91	3914	8	6	2,2

8-15 bar				
RPM	Lt/h	BAR		Kw
		std	max	
14	646	8	15	0,75
15	692	8	15	0,75
17	784	8	15	1,5
19	876	8	15	1,5
22	1014	8	15	1,5
24	1107	8	15	1,5
28	1291	8	15	1,5
30	1383	8	15	1,5
35	1614	8	15	2,2
39	1798	8	15	2,2
46	2121	8	15	2,2
50	2306	8	14	2,2
57	2628	8	12	2,2
63	2905	8	8	2,2
72	3320	8	8	2,2

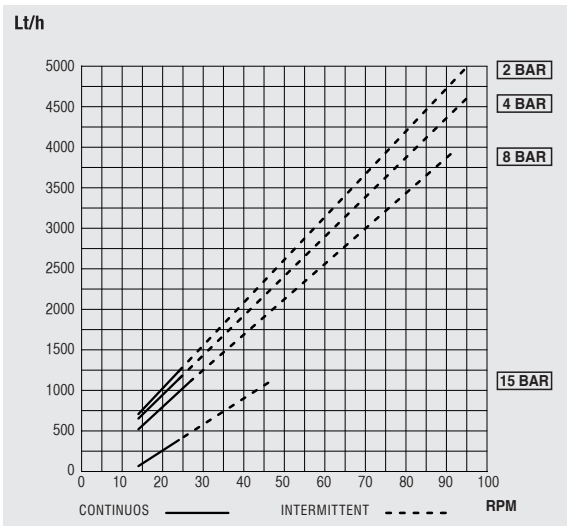

variable gear speed 0-4 bar						
RPM		Lt/h		BAR		Kw
max	min	max	min	std	max	
10	1,9	482	66	2	4	0,75
12	2,4	585	92	2	4	0,75
16	3,2	790	133	2	4	0,75
19	3,8	944	164	2	4	0,75
24	4,8	1201	215	2	4	0,75
32	6,3	1611	292	2	4	0,75
40	7,6	2022	359	2	4	1,5
50	9,5	2535	456	2	4	1,5
67	12,7	3408	621	2	4	1,5
100	19	5102	944	2	2	1,5

variable gear speed 4-8 bar						
RPM		Lt/h		BAR		Kw
max	min	max	min	std	max	
9	1,8	453	91	4	8	0,75
10	2	503	101	4	8	0,75
12	2,3	603	116	4	8	0,75
13	2,6	654	131	4	8	0,75
14	2,8	704	141	4	8	0,75
18	3,6	905	181	4	8	0,75
20	4	1006	201	4	8	0,75
21	4,2	1056	211	4	8	0,75
25	4,7	1257	236	4	8	1,5
28	5,3	1408	267	4	8	1,5
31	5,8	1559	292	4	8	1,5
34	6,4	1710	322	4	8	1,5
40	7,6	2011	382	4	8	1,5
44	8,4	2213	422	4	8	1,5
50	9,5	2514	478	4	8	2,2
55	10,5	2766	528	4	6	2,2
64	12,2	3218	613	4	6	2,2
71	13,6	3570	684	4	4	2,2



# MS1

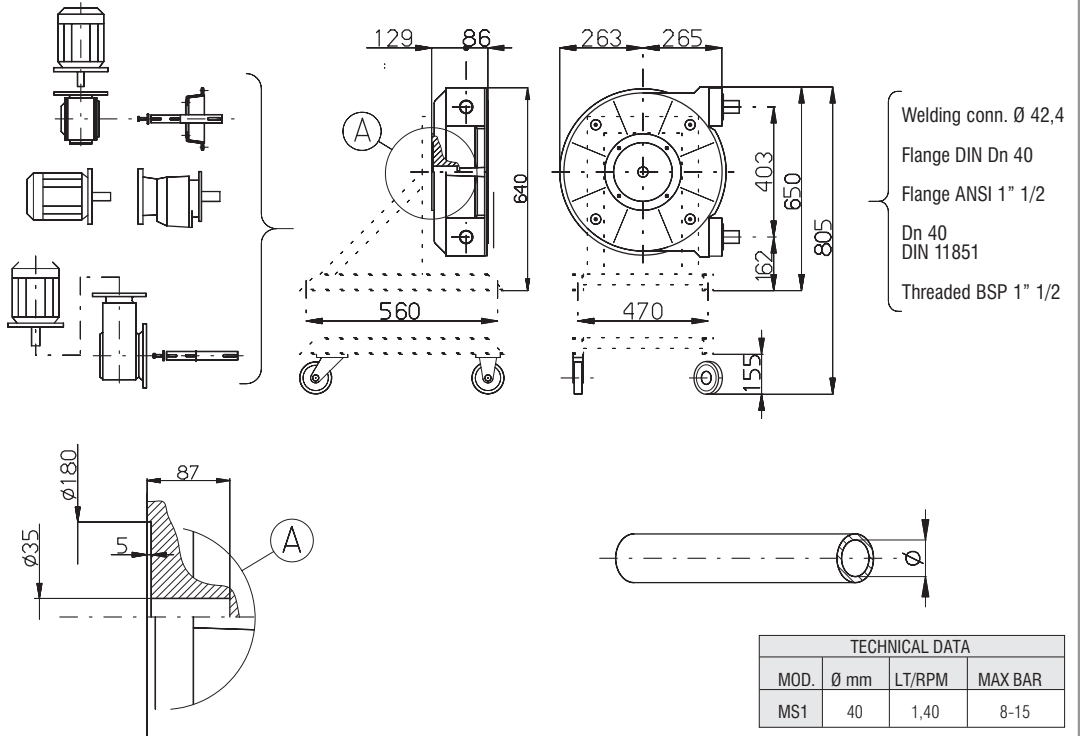

0-4 bar				
RPM	Lt/h	BAR		Kw
		std	max	
14	1114	2	4	0,75
18	1447	2	4	0,75
22	1779	2	4	0,75
25	2029	2	4	1,5
30	2445	2	4	1,5
35	2861	2	4	1,5
47	3859	2	4	1,5
61	5024	2	4	2,2
70	5773	2	4	2,2
93	7686	2	4	3

4-8 bar				
RPM	Lt/h	BAR		Kw
		std	max	
14	1090	4	8	0,75
15	1172	4	8	0,75
17	1335	4	8	0,75
19	1498	4	8	1,5
22	1742	4	8	1,5
24	1905	4	8	1,5
27	2150	4	8	1,5
30	2394	4	8	1,5
35	2802	4	8	1,5
38	3046	4	8	2,2
45	3617	4	8	2,2
49	3943	4	8	2,2
56	4513	4	8	2,2
62	5002	4	4	2,2
71	5906	2	2	2,2
79	6572	2	2	2,2
89	7404	2	2	2,2

8-12 bar				
RPM	Lt/h	BAR		Kw
		std	max	
14	843	8	12	1,5
15	918	8	12	1,5
17	1067	8	12	1,5
19	1217	8	12	2,2
22	1441	8	12	2,2
24	1590	8	12	2,2
27	1815	8	12	2,2
30	2039	8	12	3
35	2413	8	12	3
38	2637	8	12	3
45	3160	8	12	3
49	3459	8	8	3
56	3982	8	8	3
62	4430	8	8	3
71	4849	8	6	3
79	5447	8	4	3
89	6194	8	4	3

15 bar				
RPM	Lt/h	BAR		Kw
		std	max	
14	217	15	15	1,5
15	277	15	15	1,5
17	397	15	15	1,5
19	517	15	15	2,2
22	697	15	15	2,2
24	816	15	15	2,2
27	996	15	15	2,2
30	1176	15	15	3
35	1476	15	15	3
38	1655	15	15	3
45	2075	15	15	4

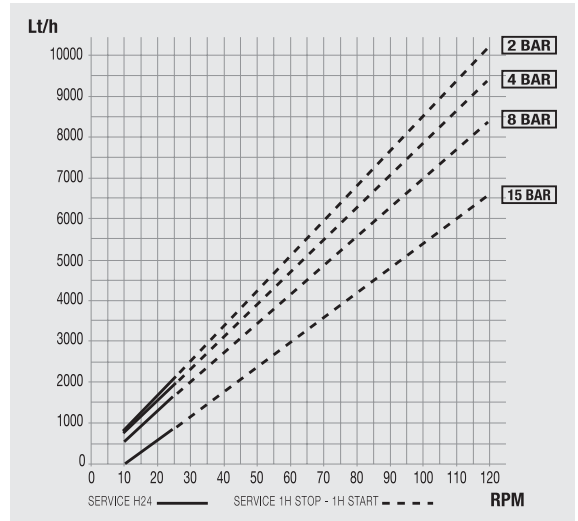

variable gear speed 0-4 bar						
RPM		Lt/h		BAR		Kw
max	min	max	min	std	max	
10	1,9	781	107	2	4	0,75
13	2,4	1031	149	2	4	0,75
16	3	1280	199	2	4	0,75
18	3,4	1447	232	2	4	0,75
22	4,1	1779	290	2	4	1,5
25	4,8	2029	349	2	4	1,5
33	6,3	2695	473	2	4	1,5
43	8,3	3526	640	2	4	1,5
50	9,5	4109	740	2	4	1,85
67	12,7	5523	1006	2	2	1,85
100	19	8268	1530	2	2	2,2

variable gear speed 4-8 bar						
RPM		Lt/h		BAR		Kw
max	min	max	min	std	max	
10	1,9	764	104	4	8	0,75
11	2	846	112	4	8	0,75
12	2,3	927	137	4	8	0,75
13	2,6	1009	161	4	8	1,5
16	3	1253	194	4	8	1,5
17	3,2	1335	210	4	8	1,5
19	3,7	1498	251	4	8	1,5
21	4	1661	275	4	8	1,5
25	4,7	1987	332	4	8	1,85
27	5,2	2150	373	4	8	1,85
32	6,1	2557	446	4	8	2,2
35	6,7	2802	495	4	8	2,2
40	7,6	3209	569	4	8	3
44	8,4	3535	634	4	8	3
51	9,6	4106	732	4	8	3
56	10,7	4513	821	4	6	3
63	12	5084	927	4	6	3
89	17	7203	1335	4	4	3

# MS2

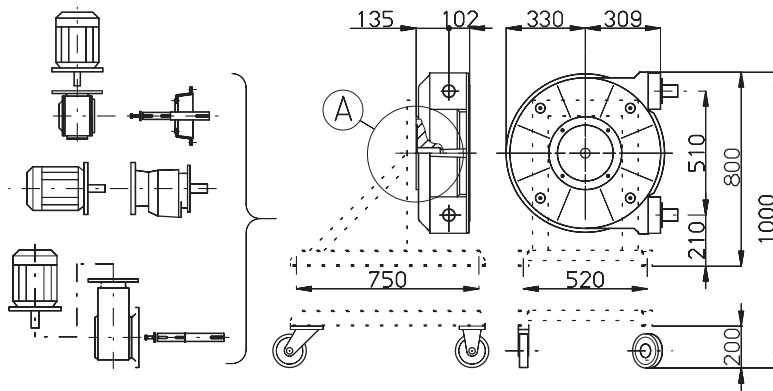

- Welding conn. Ø 60,3
- Flange DIN Dn 50
- Flange ANSI 2"
- Dn 50  
DIN 11851
- Threaded BSP 2"

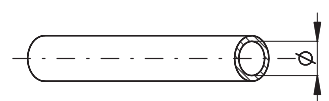
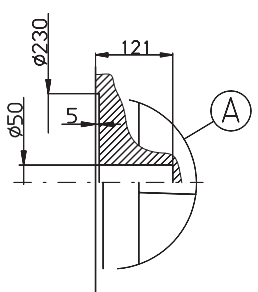
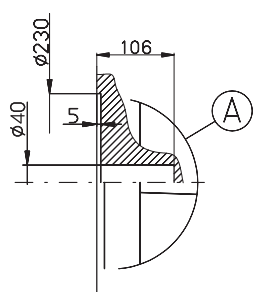

TECHNICAL DATA			
MOD.	Ø mm	LT/RPM	MAX BAR
MS2	55	3,20	8-15

0-4 bar				
RPM	Lt/h	BAR		Kw
		std	max	
14	2528	2	4	1,5
15	2717	2	4	1,5
18	3283	2	4	1,5
19	3472	2	4	1,5
22	4038	2	4	1,5
24	4416	2	4	1,5
27	4982	2	4	2,2
30	5549	2	4	2,2
35	6493	2	4	2,2
38	7059	2	4	2,2
47	8758	2	4	3
54	10080	2	4	3
60	11213	2	4	4
67	12534	2	4	4
74	13856	2	3	4
84	15744	2	2	4
93	17443	2	2	4

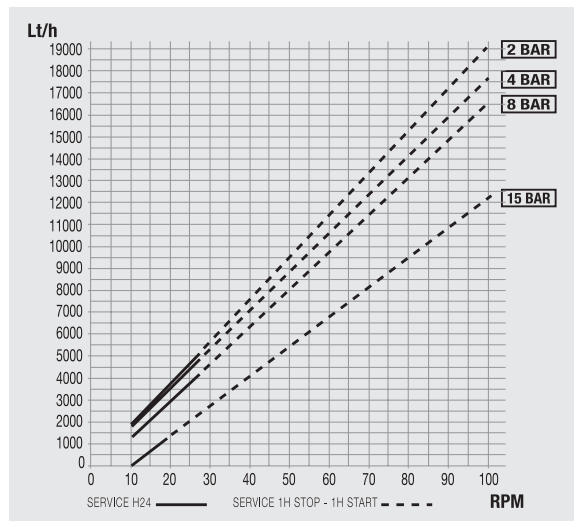

4-8 bar				
RPM	Lt/h	BAR		Kw
		std	max	
14	2474	4	8	2,2
15	2659	4	8	2,2
18	3214	4	8	2,2
19	3399	4	8	2,2
22	3954	4	8	2,2
24	4324	4	8	3
27	4879	4	8	3
30	5434	4	8	3
35	6358	4	8	4
38	6913	4	8	4
47	8578	4	6	4
54	9873	4	5	4
60	10982	4	4	4
67	12277	4	4	4
74	13226	4	3	4
84	15076	4	2	4
93	16740	4	2	4

variable gear speed 0-4 bar						
RPM		Lt/h		BAR		Kw
max	min	max	min	std	max	
10	1,9	1773	244	2	4	0,75
11	2	1962	262	2	4	0,75
13	2,4	2339	338	2	4	1,5
14	2,6	2528	376	2	4	1,5
15	2,9	2717	432	2	4	1,5
17	3,2	3094	489	2	4	1,5
20	3,7	3661	583	2	4	1,5
21	4,1	3850	659	2	4	1,5
25	4,7	4605	772	2	4	2,2
27	5,1	4982	848	2	4	2,2
33	6,3	6115	1074	2	4	2,2
39	7,3	7248	1263	2	4	3
43	8,1	8003	1414	2	4	3
48	9	8947	1584	2	4	3
53	10,1	9891	1792	2	4	4
60	11,4	11213	2037	2	4	4
67	12,7	12534	2283	2	3,5	4
85	16,1	15933	2924	2	2	4

8 bar				
RPM	Lt/h	BAR		Kw
		std	max	
14	1914	8	8	2,2
15	2083	8	8	2,2
18	2592	8	8	2,2
19	2762	8	8	2,2
22	3270	8	8	2,2
24	3610	8	8	3
27	4118	8	8	3
30	4627	8	8	3
35	5475	8	8	4
38	5984	8	8	4
47	7510	8	6	4
54	8698	8	5	4
60	9715	8	4	4
67	10902	8	4	4
74	12090	8	3	4
84	13786	8	2	4
93	15312	8	2	4

variable gear speed 4-8 bar						
RPM		Lt/h		BAR		Kw
max	min	max	min	std	max	
10	1,9	1734	236	4	8	2,2
11	2	1919	255	4	8	2,2
13	2,4	2289	329	4	8	2,2
14	2,6	2474	366	4	8	2,2
15	2,9	2659	421	4	8	2,2
17	3,2	3029	477	4	8	3
20	3,7	3584	569	4	8	3
21	4,1	3769	643	4	8	3
25	4,7	4509	754	4	8	4
27	5,1	4879	828	4	8	4
33	6,3	5988	1050	4	8	4
39	7,3	7098	1235	4	6	5,5
43	8,1	7838	1383	4	6	5,5
48	9	8763	1549	4	6	5,5
53	10,1	9688	1753	4	6	5,5
60	11,4	10982	1993	4	6	7,5
67	12,7	12277	2234	4	6	7,5
85	16,1	15606	2863	4	4	7,5

15 bar				
RPM	Lt/h	BAR		Kw
		std	max	
14	493	15	15	3
15	629	15	15	3
17	901	15	15	3
19	1173	15	15	4
21	1445	15	15	4
24	1853	15	15	4
26	2125	15	15	5
29	2533	15	15	5

variable gear speed 6-12 bar						
RPM		Lt/h		BAR		Kw
max	min	max	min	std	max	
10	1,8	1670	206	6	12	2,2
11	2,1	1849	260	6	12	2,2
12	2,3	2028	295	6	12	3
13	2,6	2206	349	6	12	3
15	2,8	2563	385	6	12	3
17	3,2	2920	456	6	12	4
19	3,6	3277	528	6	12	4
21	4	3635	599	6	12	4
28	5,3	4884	831	6	12	5,5



# MS3

MS0 MS1 MS2 MS3

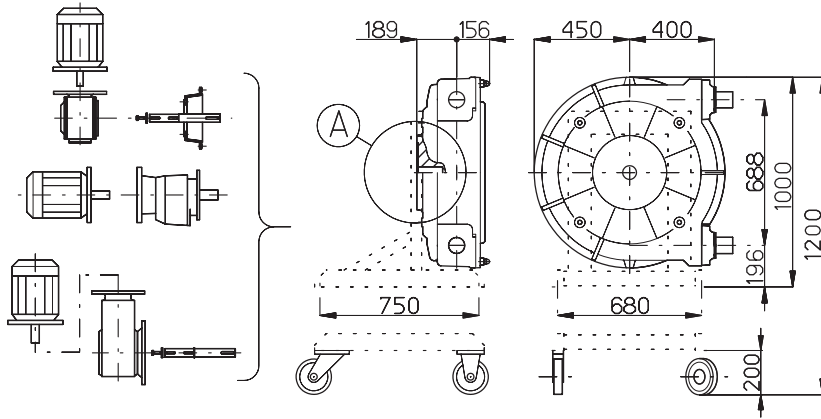

- Welding conn. Ø 76,1
- Flange DIN Dn 65
- Flange ANSI 2" 1/2
- Dn 65  
DIN 11851
- Threaded BSP 2" 1/2

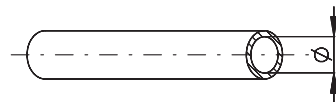
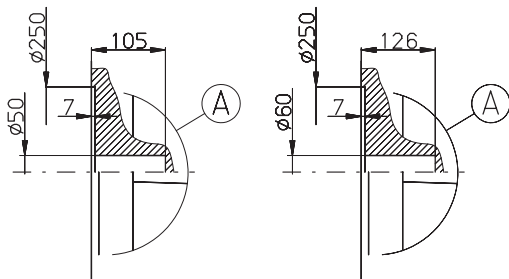

TECHNICAL DATA			
MOD.	Ø mm	LT/RPM	MAX BAR
MS3	68	6,80	8-15

0-4 bar				
RPM	Lt/h	BAR		Kw
		std	max	
14	5372	2	4	2,2
15	5773	2	4	2,2
17	6576	2	4	2,2
19	7378	2	4	2,2
21	8180	2	4	3
24	9384	2	4	3
26	10186	2	4	3
29	11390	2	4	4
32	12594	2	4	4
39	15402	2	4	5,5
42	16606	2	4	5,5
51	20216	2	4	7,5
56	22222	2	4	7,5
63	25031	2	3	7,5
71	28240	2	3	7,5
79	31450	2	2	7,5

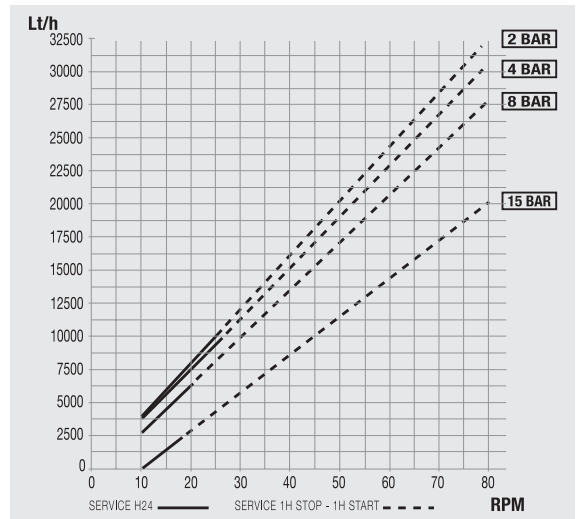

4-8 bar				
RPM	Lt/h	BAR		Kw
		std	max	
14	5258	4	8	3
15	5651	4	8	3
17	6437	4	8	4
19	7223	4	8	4
21	8009	4	8	4
24	9188	4	8	5,5
26	9974	4	8	5,5
29	11153	4	8	7,5
32	12332	4	8	7,5
39	15084	4	6	7,5
42	16263	4	6	7,5
51	19800	4	5	7,5
56	21765	4	4	7,5
63	24517	4	3	7,5
71	27661	4	3	7,5
79	30805	4	2	7,5

variable gear speed 0-4 bar						
RPM		Lt/h		BAR		Kw
max	min	max	min	std	max	
10	1,8	3767	477	2	4	2,2
11	2,1	4168	598	2	4	2,2
12	2,3	4570	678	2	4	2,2
13	2,6	4971	798	2	4	2,2
15	2,8	5773	879	2	4	2,2
17	3,2	6576	1039	2	4	4
19	3,6	7378	1200	2	4	4
21	4	8180	1360	2	4	4
23	4,4	8983	1520	2	4	4
28	5,3	10989	1882	2	4	4
30	5,8	11791	2082	2	4	7,5
36	6,9	14198	2523	2	4	7,5
40	7,7	15803	2844	2	4	7,5
45	8,5	17809	3165	2	4	7,5
51	9,7	20216	3647	2	4	7,5
56	10,7	22222	4048	2	4	7,5
63	11,9	25031	4529	2	3	7,5

8-10 bar				
RPM	Lt/h	BAR		Kw
		std	max	
13	3706	8	10	4
16	4787	8	10	4
17	5148	8	10	5,5
20	6229	8	10	5,5
21	6589	8	10	5,5
25	8031	8	10	7,5
27	8752	8	10	7,5
31	10193	8	10	11
34	11274	8	10	11

variable gear speed 4-8 bar						
RPM		Lt/h		BAR		Kw
max	min	max	min	std	max	
10	1,8	3930	707	4	8	4
11	2,2	4323	865	4	8	4
12	2,3	4716	904	4	8	4
14	2,7	5503	1061	4	8	4
15	2,9	5896	1140	4	8	4
18	3,4	7075	1336	4	8	7,5
19	3,6	7468	1415	4	8	7,5
22	4,3	8647	1690	4	8	7,5
24	4,6	9433	1808	4	8	7,5
29	5,5	11398	2162	4	8	9,2
36	6,9	14149	2712	4	6	9,2
44	8,3	17294	3262	4	6	9,2

15 bar				
RPM	Lt/h	BAR		Kw
		std	max	
13	758	15	15	7,5
16	1625	15	15	7,5
18	2203	15	15	7,5
19	2492	15	15	7,5
22	3359	15	15	11
26	4515	15	15	11
31	5960	15	12	11

variable gear speed 6-10 bar						
RPM		Lt/h		BAR		Kw
max	min	max	min	std	max	
10	1,8	3550	438	6	10	4
11	2,2	3929	590	6	10	4
12	2,3	4308	628	6	10	4
14	2,7	5067	780	6	10	5,5
15	2,9	5447	856	6	10	5,5
18	3,4	6585	1045	6	10	7,5
19	3,6	6965	1121	6	10	7,5
22	4,3	8103	1387	6	10	7,5
24	4,6	8862	1501	6	10	7,5
29	5,5	10759	1842	6	8	9,2
36	6,9	13415	2373	6	8	9,2
44	8,3	16451	2905	6	6	9,2





**BEDU**  
≡ P O M P E N ≡

## made for your process

- Expert advice
- A customer-oriented organization that adapts to the requirements and wishes of your organization
- Innovative and customized solutions
- Breakdownservice, 24 hours a day, 7 days a week
- Technical service with extensive test facilities, working from our own workplace or at your location
- A fast and appropriate solution for all your issues
- Wide range of liquid pumps
- Repair, maintenance and revision

BEDU POMPEN B.V.  
Poort van Midden Gelderland Rood 10  
6666 LT HETEREN  
Nederland  
Telefoon +31 (0)88 4802 900  
E-mail [sales@bedu.eu](mailto:sales@bedu.eu)

[WWW.BEDU.NL](http://WWW.BEDU.NL)

BEDU BELGIUM B.V.B.A.  
Industriepark-West 75  
9100 SINT-NIKLAAS  
België  
Telefoon +32 (0)3 80 87 980  
E-mail [sales@bedu.eu](mailto:sales@bedu.eu)

[WWW.BEDU.BE](http://WWW.BEDU.BE)

