

Pumping

- Aggressive, explosive and toxic liquids
- Acids & lyes
- Hydrocarbons
- Heat transfer liquids
- Liquid gases
- Liquids Difficult-to-seal
- Ultrapure liquids

Applications

- Refineries
- Chemical and petrochemical industries
- Refrigeration and heat engineering
- Liquid gas plants
- Galvanic engineering
- Power stations
- Tank installations
- Pharmaceutical industries
- Fibers industries

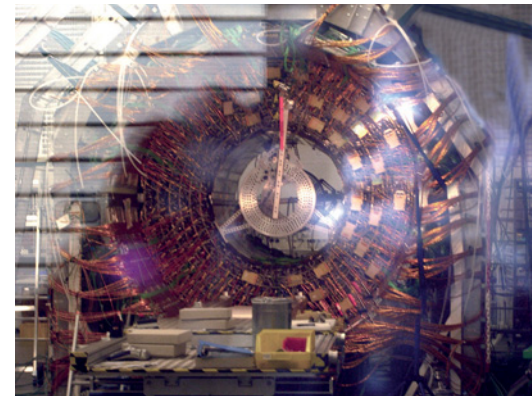
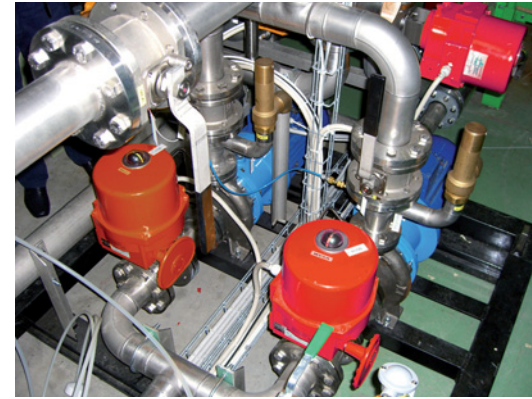

HEAVY DUTY HORIZONTAL, SEALLESS CENTRIFUGAL PUMP WITH PERMANENT MAGNET DRIVE SYSTEM, NO MECHANICAL SEAL ISO 2858 - DIN 24256



Bedu Pompen B.V.
P v M Gelderland Rood 10
6666 LT HETEREN
Tel: +31 (0)88 4802 900 - Fax: +31 (0)88 4802 901
www.bedu.eu - info@bedu.eu

CN MAG-M Series

The separation of liquid chamber/atmosphere by means of an isolation shell is the best solution to pump aggressive, explosive and toxic liquids, hydrocarbons, heat transfer liquids and liquids difficult to seal. The hermetic sealless is the best solution for the chemical, pharmaceutical and petrochemical industry. A wide range of pumps covers the different performances.

BEDU
POMPEN

CN MAG-M

General

CN MAG-M Magnetic drive pumps are sealless pumps. The static rear containment shell forms a closed system with hermetically sealed liquid end.

Applications

CN MAG-M Magnetic drive pumps are designed to improve people and plant safety. Especially when toxic, explosive or other dangerous liquids which react on contact with the atmosphere are handled. For all these services rear containment shell replaces double mechanical seals with external fluid reservoirs and all the required control devices. CN MAG-M pumps offer therefore exceptional benefits to the chemical, petrochemical and allied industries. Maximum capacity up to 4000 mc/h, differential head up to 155m. Temperature range from -185 °F (-120 °C) to +662°F (+350 °C) without external cooling. The maximum allowable working pressure 50bar for the standard version and 150bar for HP Version, higher pressure version available on request and temperature up to +842°F (+450°C).



The mag drive pumps have an extended choice of materials as well as a wide variety in models. With its 100% zero leakage mag drive coupling the mag drives are your problem solvers in fluids and chemicals transfer.

Leakproof

CN MAG-M pumps have no glands, no seals no valves. Contrary to sealed centrifugal pumps, the hermetic construction of the CN MAG-M mag drive pump ensures a safe and leak free operation. Even under heavy-duty applications the pumps are extremely reliable.

Construction

CN MAG-M are a single stage volute casing pumps with closed impellers, back-pull-out design, with end suction and top discharge flange. Sturdy legs are provided as standard for foot mounting on the base plate. Capacity and outer dimensions according to DIN 24256/ISO 2858.

**Advantages
CN MAG-M mag drive centrifugal pumps**

- Zero leakage (100% leak free)
- No mechanical seals or packed glands
- No external flushing systems
- Ensure a clean and safe operating environment, highly efficient
- Close couple and bare frame design
- No alignment required for closed couple version
- Increased Mean Time Between Maintenance

ATEX

CN MAG-M mag drive pumps can be supplied to meet the requirements of Directive 94/9/EC, with ATEX certification II -/2 G cbk II C Tx for installation in potentially explosive atmospheres.

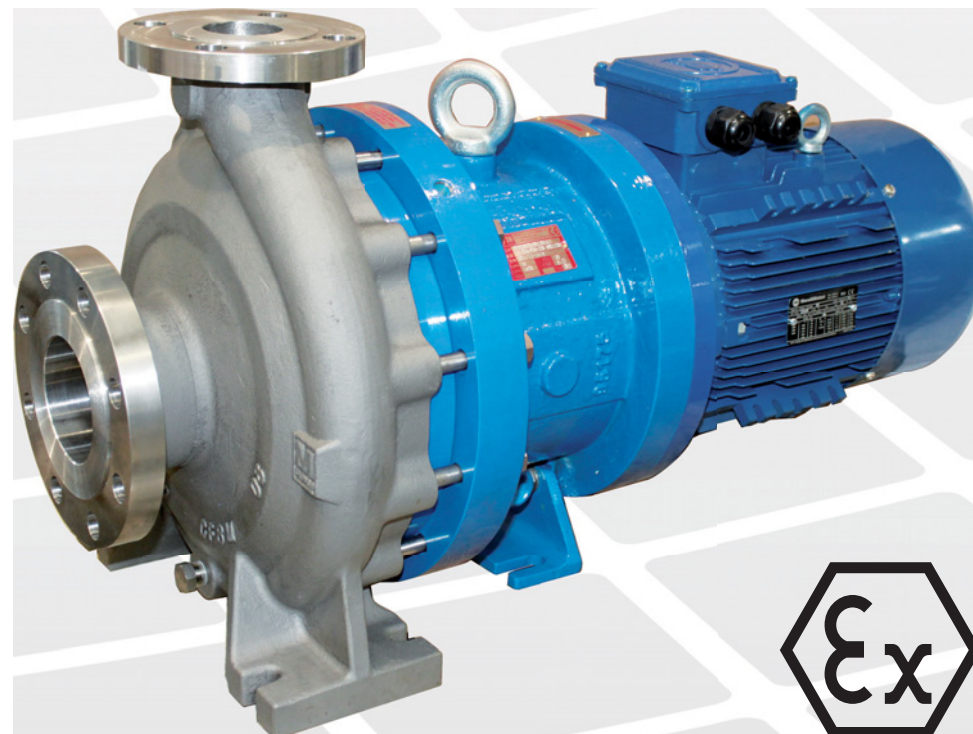

Performance curves

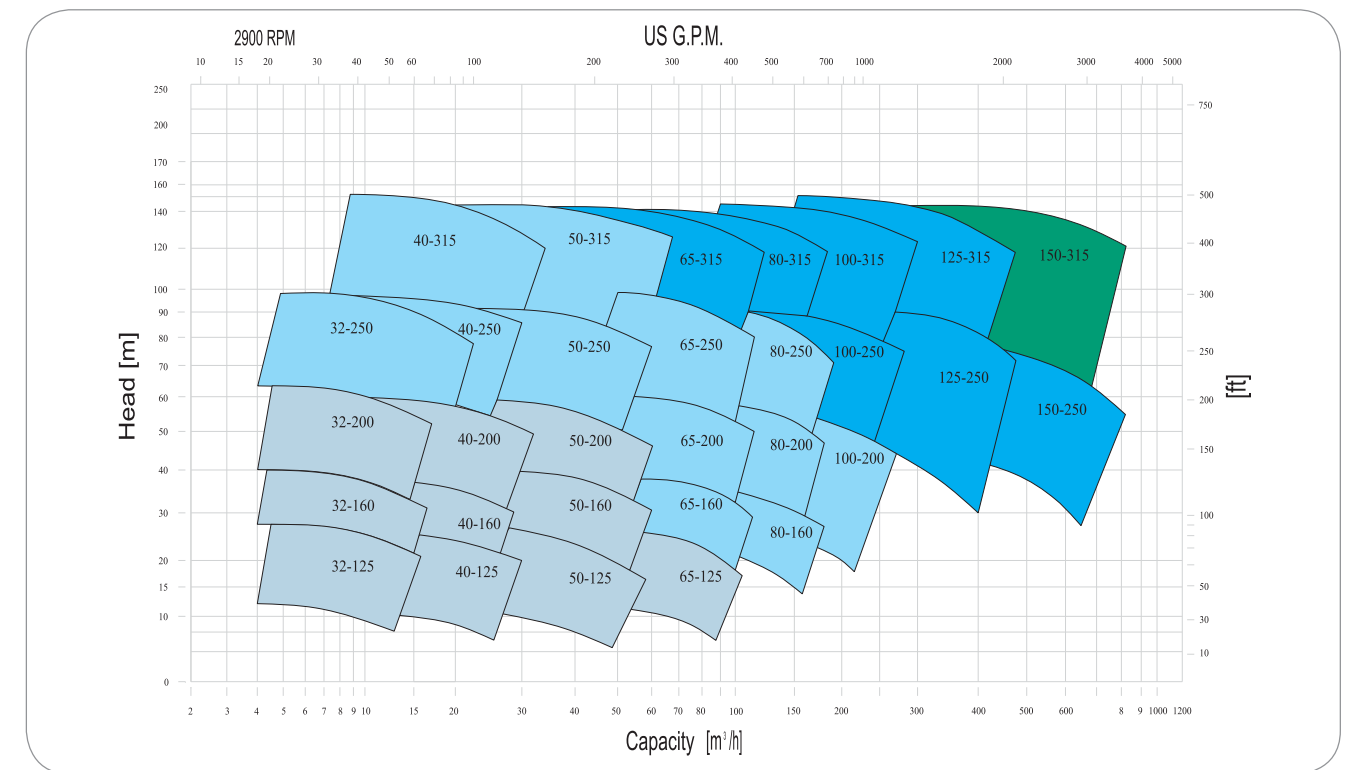
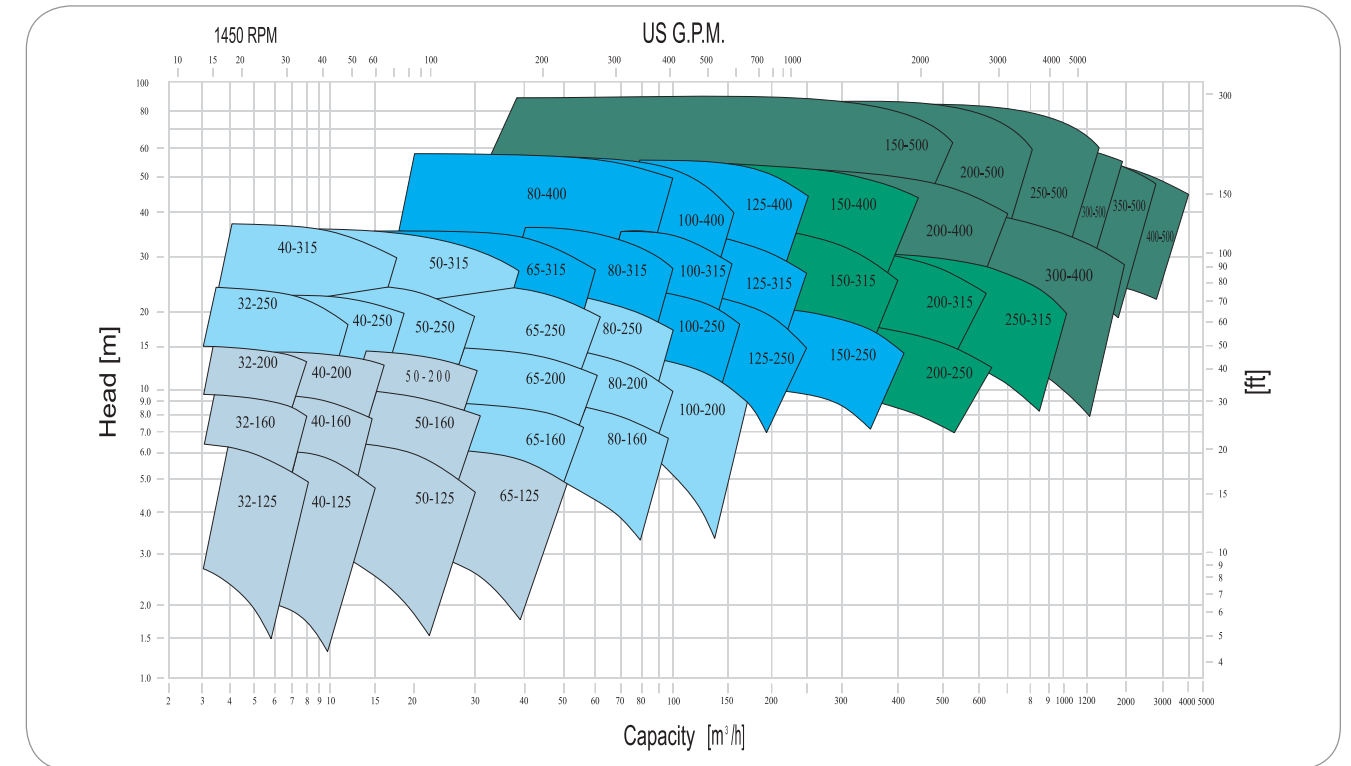

TEMPERATURES

Double slide bearings

The shaft is supported by two strong sleeve bearings. The stationary bearings are located centrally in the common bearing housing, which ensure the proper alignment for a true running. Standard material is pure alfa grade - Syntherized Silicon Carbide, highly resistant against corrosion and wear.

The Silicon Carbide parts are elastically mounted by tolerance rings, beared and designed for temperatures up to +662 °F (+350 °C) without heat exchanger.

Higher temperature on request.

Temperature control

Connections for resistant temperature detection elements, liquid and shell surface control are available as standard. Are also available on request monitoring devices for outer ball bearing.

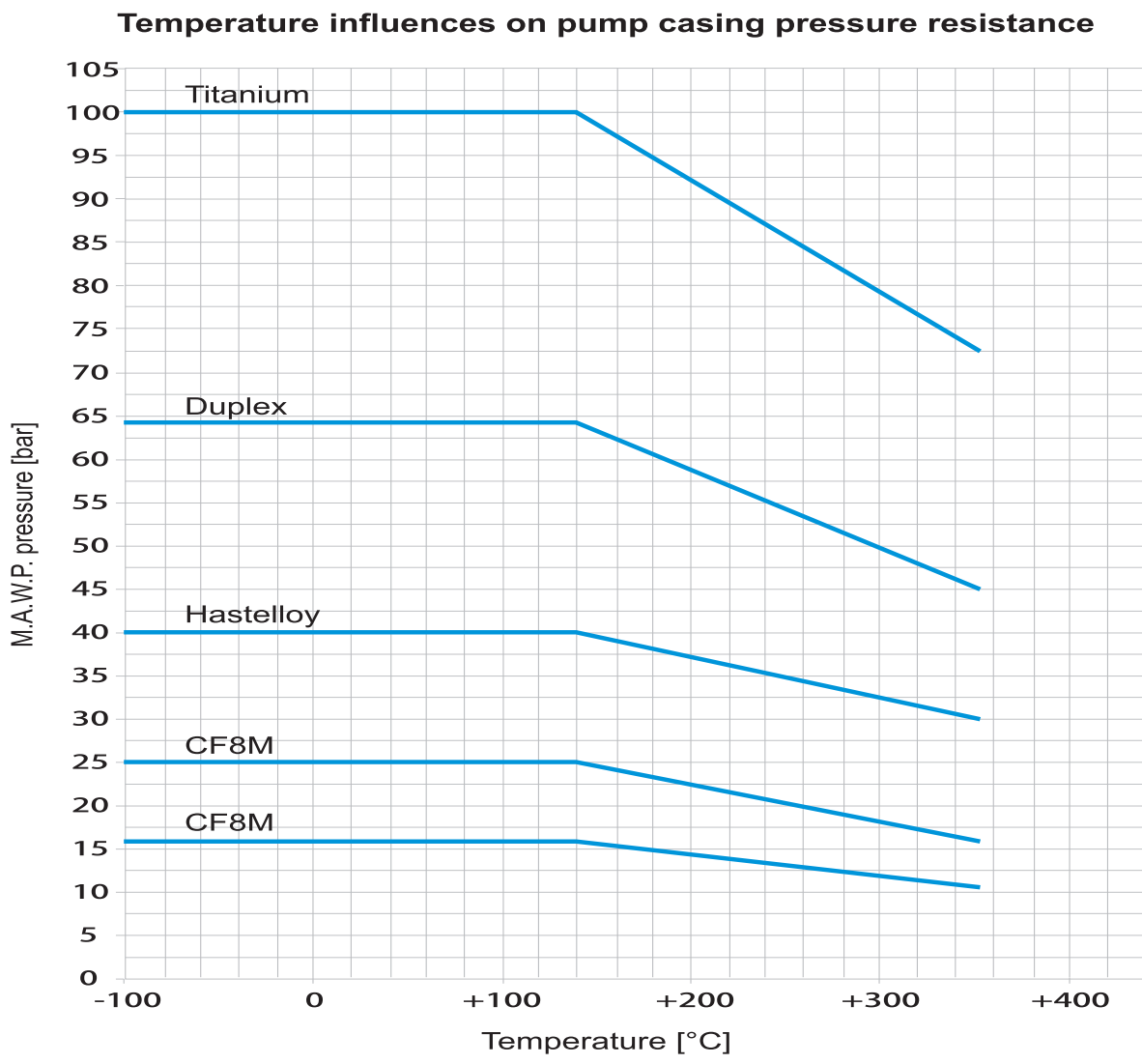
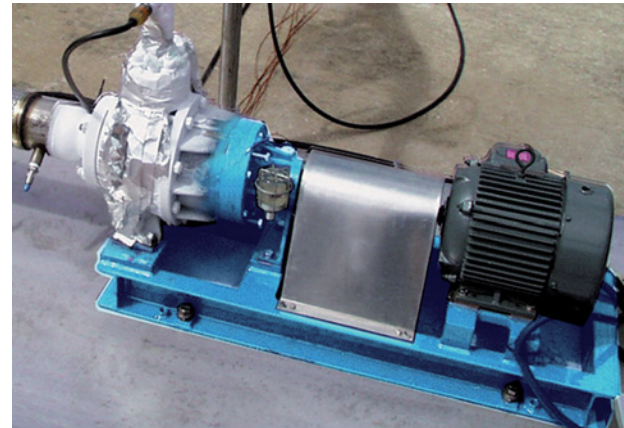

MAWP for CN MAG-M series ISO 2858 - DIN 24256

NPSH-Conditions

As the internal circulation from discharge to suction, doesn't rise temperature in the pumped liquid the handling of boiling liquids is possible without an increase of NPSH-required.

Balanced thrust loads

The thrust loads of the closed impellers are totally balanced by back vanes. Minimum residual forces that act in suction flange direction, are beared by strong silicon carbide, spring mounted, thrust bearings.

Rear containment shell protection

The clearances between the outer rotating magnets and the stationary shell and between the rotating magnet holder and bearing bracket prevent magnets from rubbing on the rear containment shell in case of ball bearing failure.

Internal circulation, pressurized containment shell area

When the pump is operating the heat generated in the containment shell and inner magnet area by eddy currents, is dissipated by an internal flow circulation from the discharge directly behind the impeller. The Pressure is increased by the rear impeller back vanes circulation, and come back to discharge.

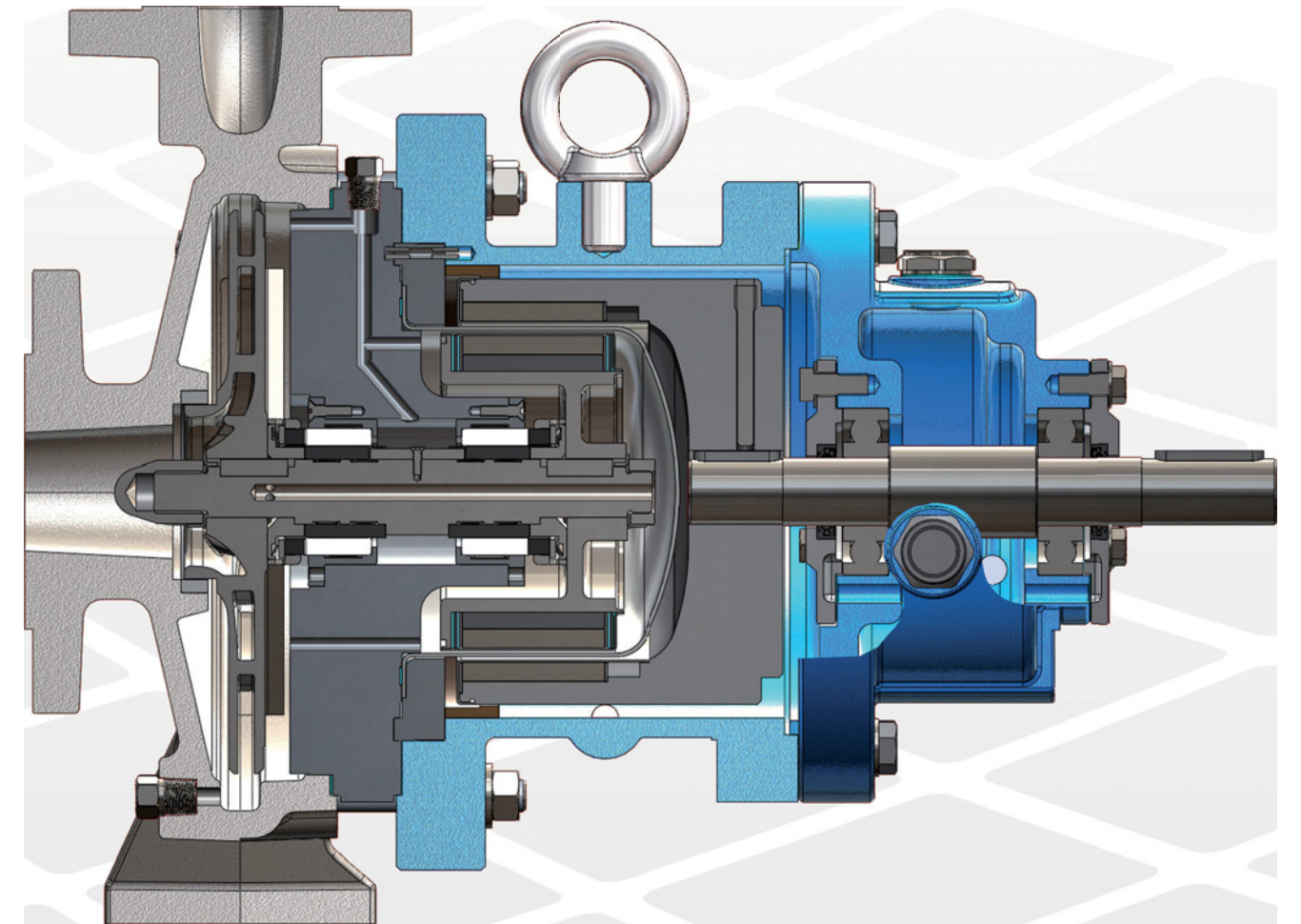

Outer ball bearings

The outer magnet shaft is fitted in generously dimensioned antifriction bearings. The bearings are L10 rated for an average life in excess of 5 years. The oil bath is protected against atmosphere by a lip seal (labyrinth oil seal on request).The oil level is controlled by a constant level oiler and additionally by a bull's eye sight glass.

Second & Third level containments

The double containment shell consists of two isolation shells placed one into the other. The gap between the two shells allows an effective monitoring via a pressure gauge or a vacuum system. Any alarm to interior or exterior shell will produce an alarm signal before any leakage occurs. On request, a mechanical seal can be supplied in place of the lip seal. The mechanical seal separates the magnet area from the oil bath and atmosphere, and together with the closed bearing housing forms a third containment after the double containment shell.

PUMP DETAILS

Epoxy primer and polyacrylic enamel water-based painting for the best quality resistance linked to the environmental respect.

CF8M Pump Casing & Impeller High quality casting components.

- Other materials:
- Hastelloy® C276,
 - Incoloy® 825,
 - Duplex,
 - Titanium,
 - Other materials available on request.

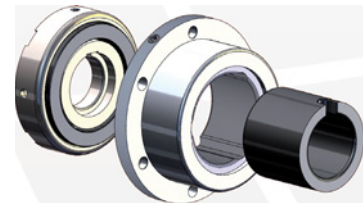

Field assembling of the product lubricated bearing arrangement does not require special tools. The Bearing materials available are of three different types to provide the best solution for each application: Silicon Carbide (SSIC), Tungsten Carbide (WC). Special configuration with PEEK composite compound for improved cavitation transitory resistance. The use of elastic rings reduces the sleeve bearing loads and the thrust bearing loads to a minimum, to guarantee many years of maintenance-free operation.

RWP QUICK CHANGE CARTRIDGE KIT to guarantee an easy and fast maintenance.



Closed impeller statically and dynamically balanced. The axial thrusts are balanced by back vanes. This allows the best balancing of axial thrusts without regards of suction pressure.

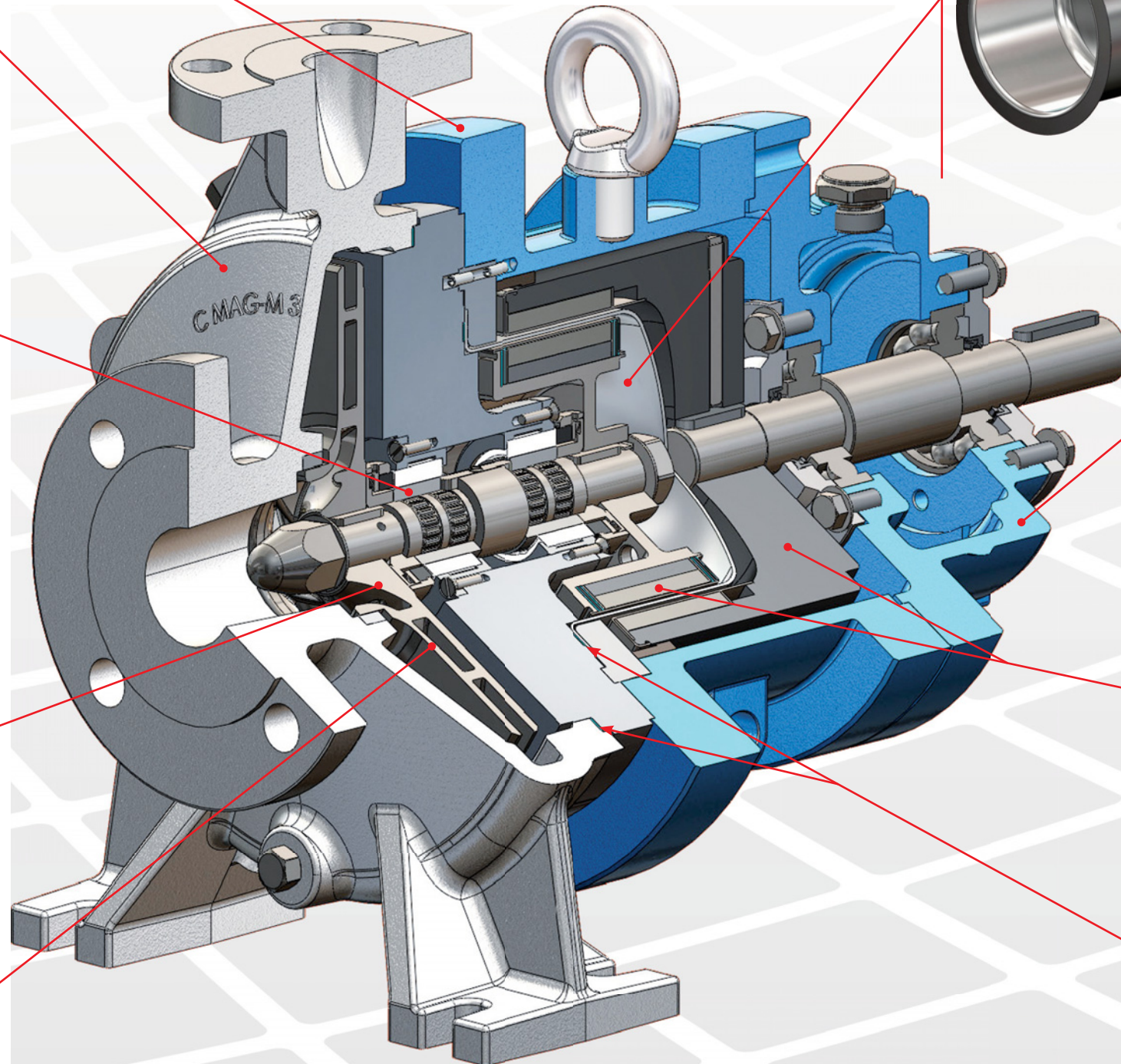

Rear shell is made of one single piece, no welding, ellipsoidal profile that has been studied to withstand higher pressures than the traditional one. Hastelloy® C276 is standard isolation shell material - providing a safe and efficient solution - system pressure max 16 bar. Hybrid rear casing technology available for energy saving configuration. Titanium Alloy is an upgrade when higher pressure ratings and increased efficiency are required. Double rear shell on request.

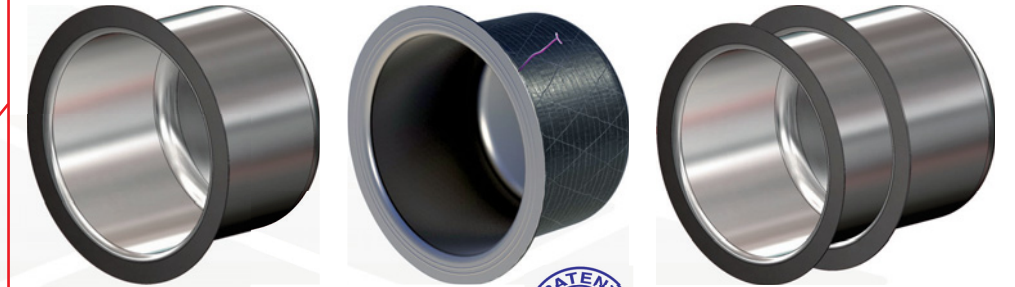

FILE NUMBER:
PD2010A000249



Close couple and bare shaft version

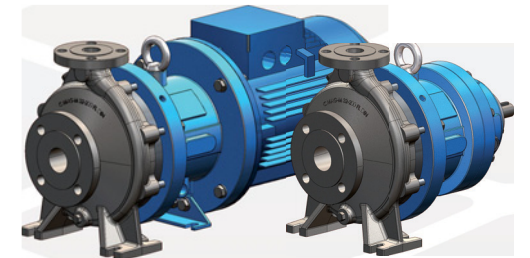

High power synchronous magnetic coupling designed by our Technical Office and with rare earth magnetic elements mechanically locked. The high performance magnets can operate at liquid temperature of up to 662 °F (350 °C) without external cooling. Installed power over 500 kW / 700 HP.

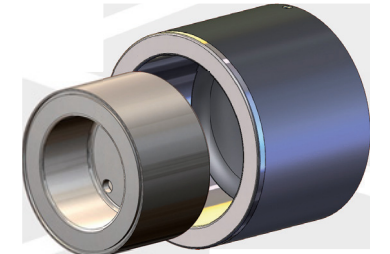

Sealing system with flat gaskets prevents from leaking in the atmosphere - different materials available:

- Asbestos free (standard)
- PTFE
- Graphoil
- GYLON®
- Spiral Wound
- Other on request

BEDU
≡ POMPEN ≡

Hybrid Technology

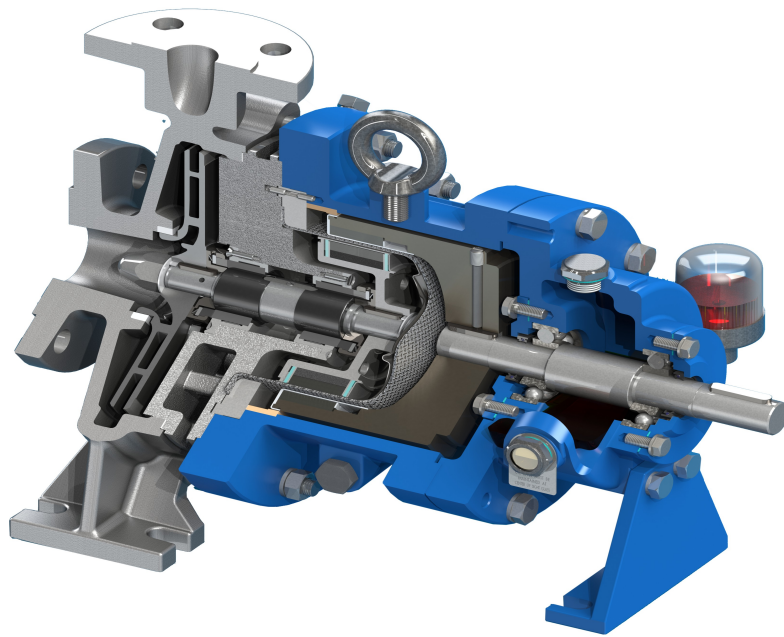

made for your process

Be Efficient!



Installation of an Hybrid Rear Shell on a large (1000 kW motor power) magnetic driven process pump.

Ease of both installation and maintenance.

M PUMPS Hybrid Technology is the most advanced and attractive ENERGY SAVING solution available now in the market:

- Less powerful installed motors (competitive initial offering).
- Lower power consumption (very low Total Cost of Ownership for end user).

The below chart shows yearly energy saving values (based on 0,12 €/kwh).

Main Advantages

- Impressive reduction in Magnetic losses
- High Pressure design: vacuum to 50 bar g
- High Temperature design: -90 °C to 200 °C
- Motor power installation up to 1000 kW

Hybrid Rear Casing energy saving comparator				
MAX. INSTALLED POWER [kW]	MAG-LOSSES [kW] WITH TRADITIONAL TECHNOLOGIES	MAG-LOSSES [kW] WITH HYBRID TECHNOLOGIES	COST SAVING EURO/year	ROTATION SPEED (RPM)
4	1,40	0,36	910,00	2900
5,5	1,70	0,70	870,00	2900
15	2,60	0,78	1.590,00	2900
22	4,00	1,04	2.590,00	2900
37	6,00	1,56	3.880,00	2900
75	8,70	2,30	5.600,00	2900
90	9,40	2,80	5.780,00	2900
180	19,00	5,60	11.730,00	2900
270	27,00	8,40	16.730,00	2900
200	6,70	2,50	3.670,00	1450
300	13,40	5,00	7.350,00	1450
400	20,10	7,50	11.030,00	1450
500	26,80	10,0	14.710,00	1450
600	* 33,50	12,5	18.390,00	1450
700	* 40,20	15,0	22.070,00	1450
800	* 46,90	17,5	25.750,00	1450
900	* 53,60	20,0	29.430,00	1450
1000	* 60,30	22,5	33.110,00	1450

*** With these high installed powers and relevant magnetic losses, the use of traditional containment shells is not possible, M PUMPS only is able to supply these sizes of magnetic drive pumps.**

Available on all M PUMPS Process Pumps

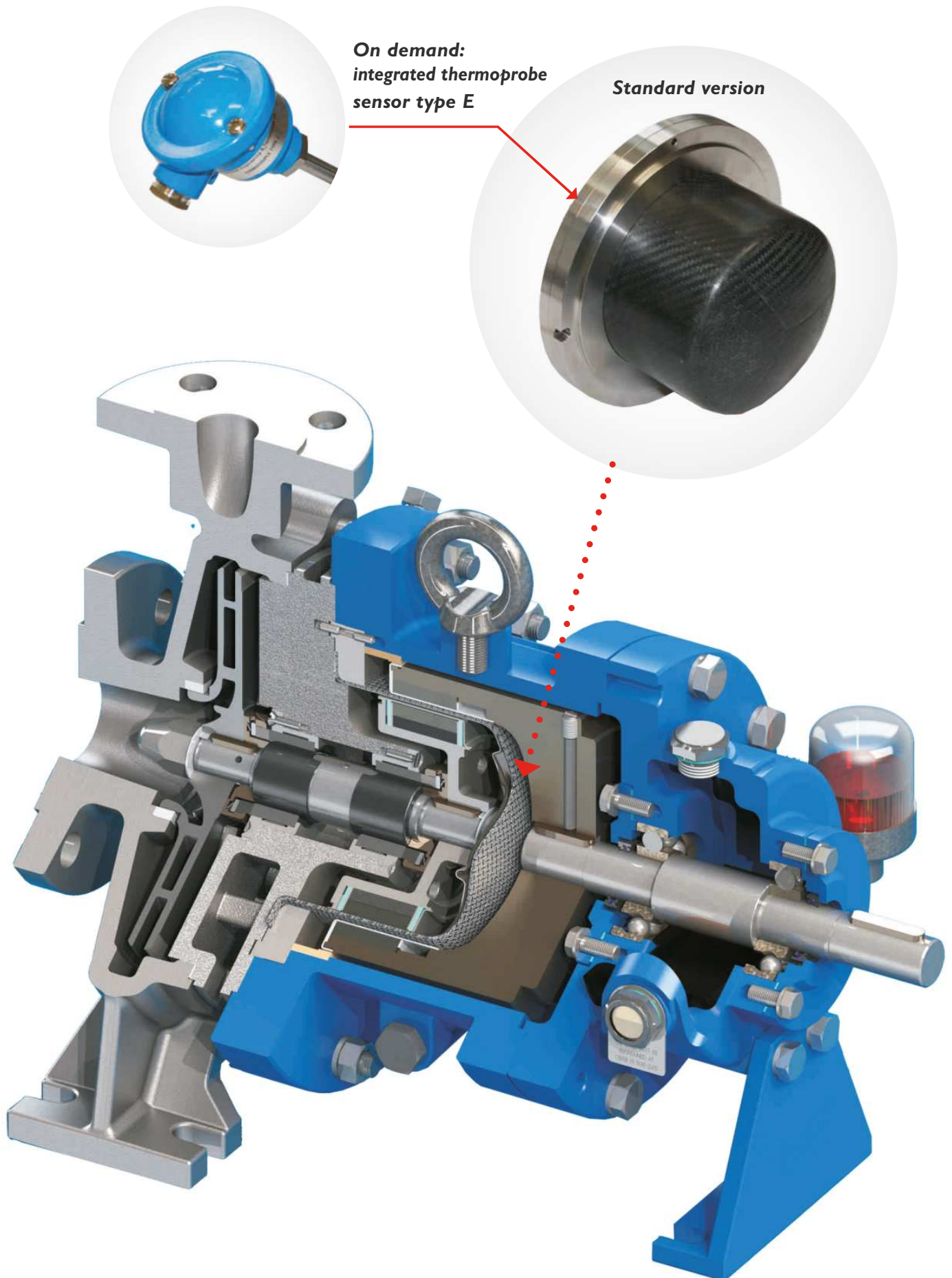

Mag Losses and Heat Reduction

Table shown below is a comparison between M PUMPS and other rear shell solutions available currently on the market.

Hybrid shell containment comparison (*)						
	MATERIAL	DES PRESS (bar)	DESIGN TEMP °C	MAG-LOSSES (kW)	NOTES	
HYBRID M PUMPS	HASTELLOY C / CARBON FIBER	50	-90/+200°C	0,78	EXTREMELY RELIABLE/SUITABLE FOR TEMP. PROBE/GREAT PRICE ADVANTAGE	
	COMPETITORS	ZIRCONIUM OXYDE	16	-190/+350°C	/	HIGH COST AND MUCH LOWER PRESSURE
		METAL ZIRCONIUM OXYDE	16	-190/+350°C	1,5	HIGH COST, MUCH LOWER PRESSURE AND HIGHER MAG LOSS COMPARED TO M PUMPS
		COMPOSITE PEEK	16(≤ 20 °C)	-40/+ 120°C	/	HIGH COST AND PRESSURE AND TEMPERATURE LIMITATION
		PTFE - CARBON FIBER	16	-20/+ 200°C	/	PRESSURE LIMITS AND OVERSIZING OF MAGNET (DE-COUPLING RISK)
		BOROSILICATE GLASS	10	-40/+ 180°C	/	PRESSURE LIMITS, VERY FRAGILE AND HIGH COST (OVERSIZED MAGNET)

(*) Comparison with installed motor 18,5 kW, 2 poles, 50 Hz.

Minimized Temperature rising on rear casing region

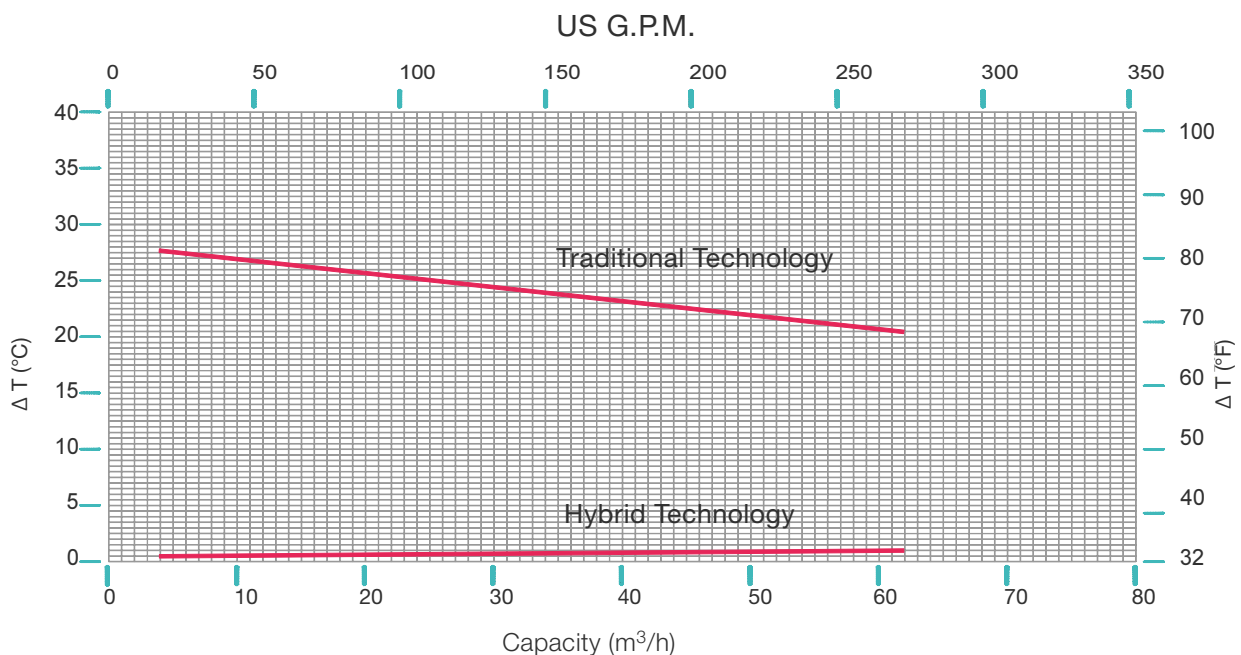

Hybrid technology reduces greatly heat generation in the rear casing region. This benefit is particularly important when pumping low boiling liquids.

Most Advanced Rear Containment Shell on the Market

Thanks to our 40 years of experience in magnetic drive technology, M Pumps is able to supply innovative and unique rear containment shell on magnetic drive pumps to enhance the competitiveness and operational efficiency in today's process industry.

As technology advances, the need for high pressure, high temperature and energy efficiency become the top priorities among pump users. Staying ahead of these priorities required M Pumps to adopt a forward thinking and proactive approach to pump design. Based on this Philosophy, M Pumps has created an advanced High pressure, High Temperature and Energy efficient Rear Containment Shell to eliminate the various concerns on the use of magnetic driven pumps in the process industry.

The patented hybrid technology containment shell combines the reliability of a standard inner metallic shell (High Pressure and High Temperature) with the strength of Carbon Fibre outer shell to achieve an energy efficient (Reduction in magnetic loss and cost of ownership) and environmental friendly (Hermetically sealed) solution.

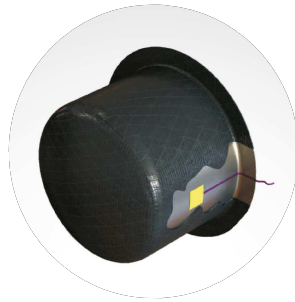

Hybrid Containment Shell with thermocouple

Our Hybrid containment shell consists of a dual shell system.

The external shell is made of carbon fiber, and the internal shell is made of Hastelloy® C or Titanium. Using carbon fiber on the External guarantees the highest mechanical strength and the internal metallic shell ensures optimal chemical compatibility. We offer optional temperature monitoring.

The Temperature sensor installed between

the inner and outer shell is located at the source of the magnetic field to provide accurate temperature reading and timely response to avoid costly pump failure.

In addition to generating much lower temperatures compared to other metallic versions, the thin shell of Hastelloy® C, guarantees immediate and accurate reading of temperature changes.

Traditional solid metallic Shell Containments with thermocouple PT100 see delays in reading temperature, possibly resulting in pump failure.

Rear shells: When «minimum» is better than «zero»

Years of development have led 3M PUMPS to develop a completely innovative technology for manufacturing rear shells.

It is a well-known fact that Eddy current losses are the “Achilles’ heel” of hermetic pumps.

These losses are caused by the rotation of the magnetic field linked up to the magnetic coupling and are inevitable when the rear shell of the pump is made of metal, albeit of noble titanium.

Broadly speaking, this leads to an oversizing of installed power, thereby reducing overall machine efficiency.

Various technologies currently exist for manufacturing rear shells in non-metallic materials, which we shall briefly analyse here:

- Rear shell made of zirconium oxide - requires considerable thickness, has only modest mechanical properties, cannot withstand high thermal shocks and is very expensive.
- Rear shell made of glass - a solution adopted for small pumps, it is very fragile, similarly limited in terms of mechanical resistance, suffers thermal shocks and is not well-regarded by maintenance personnel.
- Rear shell made of PEEK matrix composite - requires considerable thickness to guarantee a perfect seal, poor mechanical resistance, temperature limits, extremely expensive.



FILE Number:
PD2010A000249



Rendering of an HP rear shell
Maximum pressure: Hydrotest 310 bar
Maximum running temperature: 200°C
for a centrifugal pump with installed power of 500 kW
Magnetic losses: 8 kW

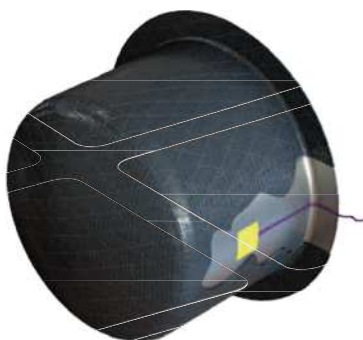

Rendering of a CN MAG-M 1°R rear shell
Maximum installable power of 22 kW
Magnetic losses: 720 W
Maximum pressure: Hydrotest 75 bar
Maximum running temperature: 200°C
New standard available on all series pumps
Also available as an upgrade to already-installed machines

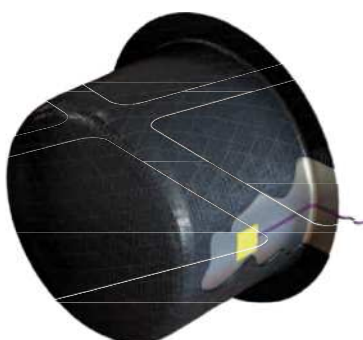

Rendering of a CN MAG-M 2°R HT rear shell
Maximum installable power of 75 kW
Magnetic losses: 1900 W
Maximum pressure: Hydrotest 75 bar
Maximum running temperature: 350°C
New standard available on all series pumps
Also available as an upgrade to already-installed machines

The Hi-brid rear shell consists of two parts: with an inner shell in Hastelloy C, and an outer one, consisting of a carbon filament wrapped around the former, it combines the extreme reliability and chemical resistance of the Nickel alloy with the impressive resistance of the composite with high modulus matrix epoxy.

From experience gathered in the military and competitive racing fields, composites are now available with outstanding characteristics, such as resistance to temperatures above 300°C.

Added to that is the possibility of constantly monitoring the temperature of the process without external devices.

This is possible thanks to a special miniaturised probe, which is inserted at the exact level of the magnetic field, between the fibres of the composite, in direct contact with the metal shell, which enables the temperature of the process to be read with a precision never seen before, without any need for power monitors.

All this has given rise to a new product with unprecedented performance levels.

The numbers speak for themselves:

magnetic losses reduced by 90% as compared to traditional solutions;

pressure resistance: up to 500 bar;

temperature resistance: up to 350°C;

material in contact with liquid: Hastelloy C / Titanium;

as standard: miniaturised probe inserted in the composite for more efficient temperature monitoring.

Our experience:

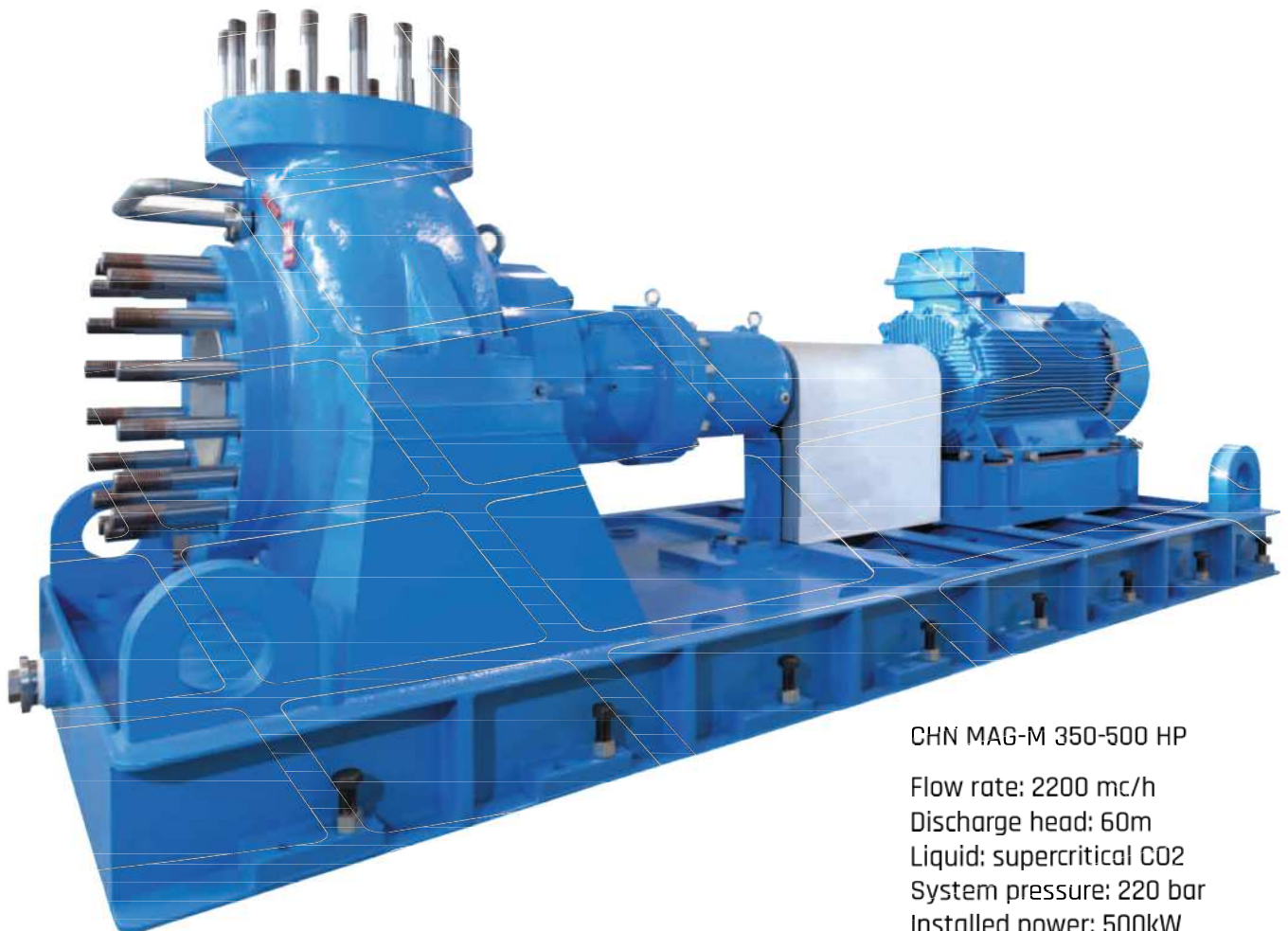

CHN MAG-M 350-500 HP

Flow rate: 2200 mc/h

Discharge head: 60m

Liquid: supercritical CO₂

System pressure: 220 bar

Installed power: 500kW

Magnetic losses: 8 kW

The logo for BEDU POMPEN is centered in a white square. It features the word "BEDU" in a large, bold, white sans-serif font. Below it, the word "POMPEN" is written in a smaller, white sans-serif font, flanked by two horizontal white bars on each side.

BEDU
POMPEN

made for your process

- Expert advice
- A customer-oriented organization that adapts to the requirements and wishes of your organization
- Innovative and customized solutions
- Breakdownservice, 24 hours a day, 7 days a week
- Technical service with extensive test facilities, working from our own workplace or at your location
- A fast and appropriate solution for all your issues
- Wide range of liquid pumps
- Repair, maintenance and revision

BEDU POMPEN B.V.
Poort van Midden Gelderland Rood 10
6666 LT HETEREN
Nederland
Telefoon +31 (0)88 4802 900
E-mail sales@bedu.eu

WWW.BEDU.NL

BEDU BELGIUM B.V.B.A.
Industriepark-West 75
9100 SINT-NIKLAAS
België
Telefoon +32 (0)3 80 87 980
E-mail sales@bedu.eu

WWW.BEDU.BE

