

Special alloy pumps



General characteristics

- Special alloy pumps
- 0,37 ÷ 1,5 kW motor power
- 2 / 4 poles
- GAS 2" V - DN65 - DN80 delivery port
- max 60 mm free passage

Electromechanical assembly

Electromechanical assembly in CF-8M (AISI 316) stainless steel, for submerged operation. Seal set comprising 2 (two) silicon carbide mechanical seals assembled opposing and with oil lubrication. Oil bath motor. Separate pump body. Series not available in explosion-proof version.

Applications

Ideal for lifting strongly corrosive or aggressive strained liquids, especially in the chemical industry. Intended for specific industrial applications.

Construction materials

Case	Cast Stainless Steel - CF-8M (AISI 316)
Impeller	Stainless steel
Nuts and bolts	Stainless Steel - Class A4-70
Standard gasket	Rubber - VITON
Shaft	Stainless Steel - AISI 316
Set of standard mechanical seals	Two Silicon carbide mechanical seals (2SiC)

operating limits

Maximum operating temperature	40 °C
PH of treated fluid	5 to 10 pH
Viscosity of treated fluid	1 mm ² /s
Maximum immersion depth	20 m
Density of treated fluid	1 Kg/dm ³
Maximum acoustic pressure	70 dB
max starts per hour	20

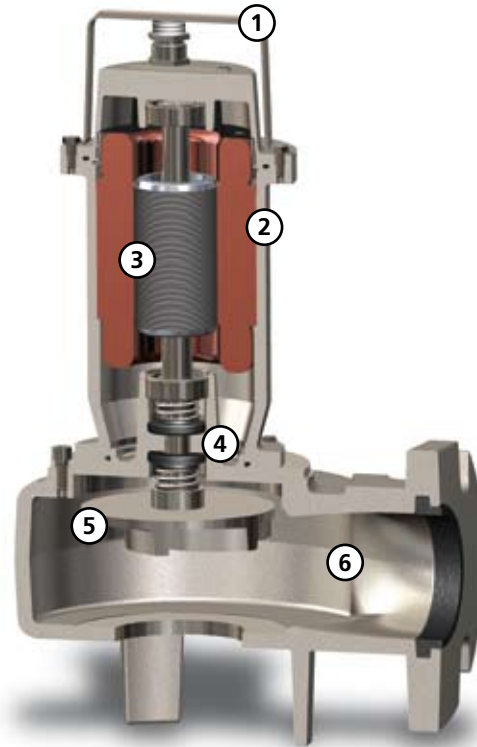

Handle and cable gland

AISI 316 stainless steel lifting and carrying handle. A rigid or flexible duct can be fixed to the cable gland to protect the power supply cable



Structure

CF-8M steel construction which makes the pump suitable for use in saline environments

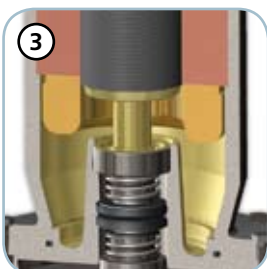

Motor

Oil-bath motor with thermal overloads



Mechanical seals

Two mechanical seals in silicon carbide (2SiC)



Impeller

Vortex impeller in CF-8M steel

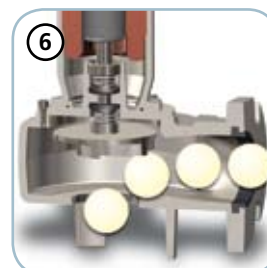

Free passage

Ample free passage allowing the expulsion of solids and preventing fouling of the impeller

DGX

Models with vertical GAS 2" threaded delivery port - 2 poles

Performances

	l/s	0	1	2	3	4	5	6	7	8	9	10
	l/min	0	60	120	180	240	300	360	420	480	540	600
	m ³ /h	0	3,6	7,2	10,8	14,4	18,0	21,6	25,2	28,8	32,4	36,0
① DGX 50/2/G50V A0CM(T)/50		7,6	6,5	5,4	4,3	3,2	2,1					
② DGX 75/2/G50V A0CM(T)/50		8,4	7,4	6,3	5,3	4,3	3,3	2,4				
③ DGX 100/2/G50V A0CM(T)/50		12,1	11,1	10,0	8,9	7,8	6,7	5,4	4,2	2,9		
④ DGX 150/2/G50V A0CM(T)/50		13,9	12,8	11,7	10,6	9,4	8,2	7,0	5,8	4,6	3,3	
⑤ DGX 200/2/G50V A0CM(T)/50		14,9	13,7	12,6	11,5	10,3	9,1	7,9	6,7	5,5	4,2	2,9

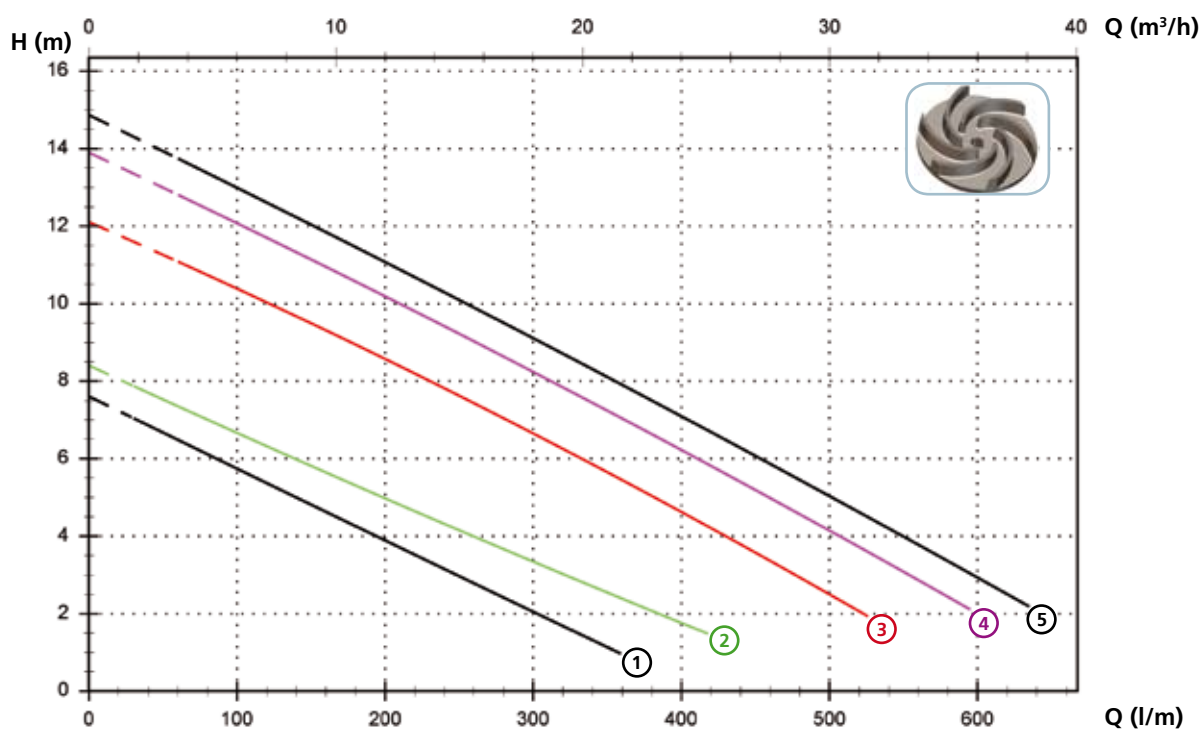

Technical data

	V	Phases	P1 (kW)	P2 (kW)	A	Rpm	Ø	Cable (*)	Free passage
① DGX 50/2/G50V A0CM/50	230	1	-	0.37	2.9	2900	G 2"	A	38 mm
② DGX 75/2/G50V A0CM/50	230	1	-	0.55	3.9	2900	G 2"	A	38 mm
③ DGX 100/2/G50V A0CM/50	230	1	-	0.88	6.5	2900	G 2"	A	38 mm
④ DGX 150/2/G50V A0CM/50	230	1	-	1.1	8.2	2900	G 2"	A	38 mm
⑤ DGX 200/2/G50V A0CM/50	230	1	-	1.5	9.3	2900	G 2"	A	38 mm

	V	Phases	P1 (kW)	P2 (kW)	A	Rpm	Ø	Cable (*)	Free passage
① DGX 50/2/G50V A0CT/50	400	3	-	0.37	1.1	2900	G 2"	A	38 mm
② DGX 75/2/G50V A0CT/50	400	3	-	0.55	1.42	2900	G 2"	A	38 mm
③ DGX 100/2/G50V A0CT/50	400	3	-	0.88	2.3	2900	G 2"	A	38 mm
④ DGX 150/2/G50V A0CT/50	400	3	-	1.1	2.7	2900	G 2"	A	38 mm
⑤ DGX 200/2/G50V A0CT/50	400	3	-	1.5	3.5	2900	G 2"	A	38 mm

(*) A = H07RN-F 4G1 - 10 m

Models with horizontal DN65 PN10-16 flanged delivery port - 2 poles

Performances

	l/s	0	2	4	6	8	10	12	14
	l/min	0	120	240	360	480	600	720	840
	m ³ /h	0	7,2	14,4	21,6	28,8	36,0	43,2	50,4
① DGX 150/2/65 A0CM(T)50		9,1	8,5	7,7	6,7	5,5	4,1	2,5	
② DGX 200/2/65 A0CM(T)50		9,6	9,1	8,4	7,5	6,4	5,1	3,7	2,0

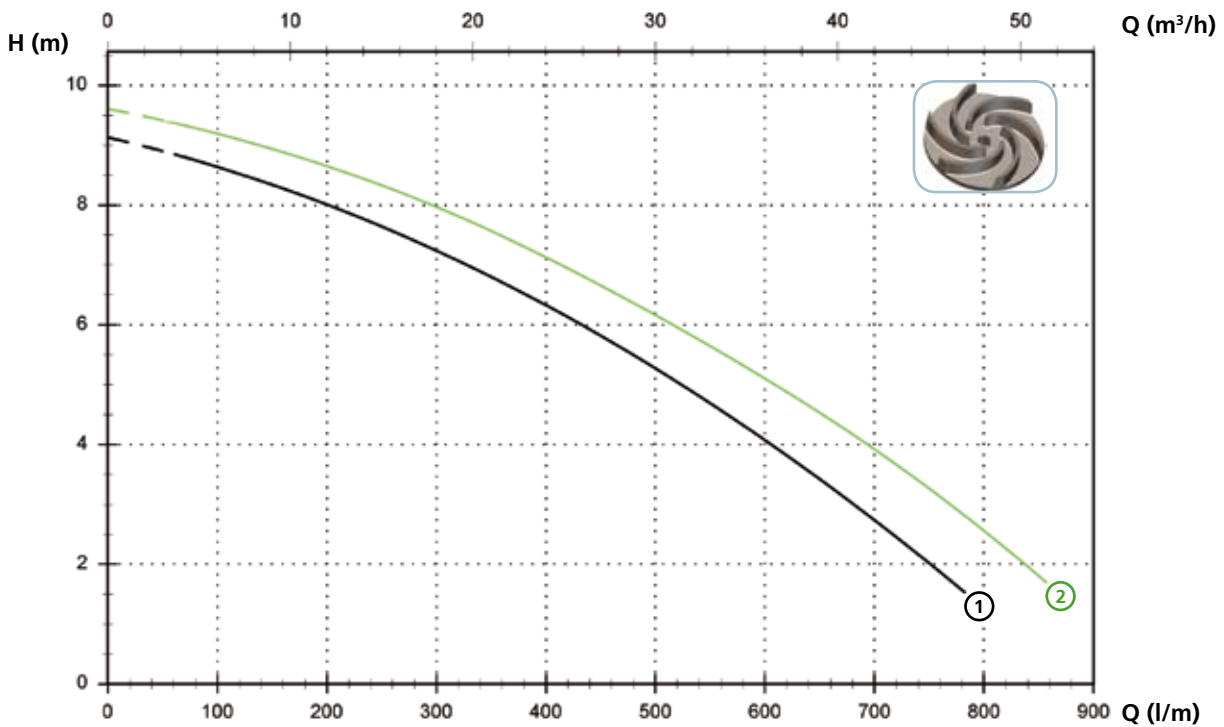

Technical data

	V	Phases	P1 (kW)	P2 (kW)	A	Rpm	Ø	Cable (*)	Free passage
① DGX 150/2/65 A0CM/50	230	1	-	1.1	8.2	2900	DN65 PN10-16	A	50 mm
② DGX 200/2/65 A0CM/50	230	1	-	1.5	9.3	2900	DN65 PN10-16	A	50 mm

	V	Phases	P1 (kW)	P2 (kW)	A	Rpm	Ø	Cable (*)	Free passage
① DGX 150/2/65 A0CT/50	400	3	-	1.1	2.7	2900	DN65 PN10-16	A	50 mm
② DGX 200/2/65 A0CT/50	400	3	-	1.5	3.5	2900	DN65 PN10-16	A	50 mm

(*) A = H07RN-F 4G1 - 10 m

DGX

Models with horizontal DN80 PN10 flanged delivery port - 2 poles

Performances

	l/s	0	2	4	6	8	10	12	14	16
	l/min	0	120	240	360	480	600	720	840	960
	m ³ /h	0	7,2	14,4	21,6	28,8	36,0	43,2	50,4	57,6
① DGX 200/2/80A A0CM(T)/50		8,1	7,5	6,8	5,9	5,1	4,3	3,5	2,7	1,9

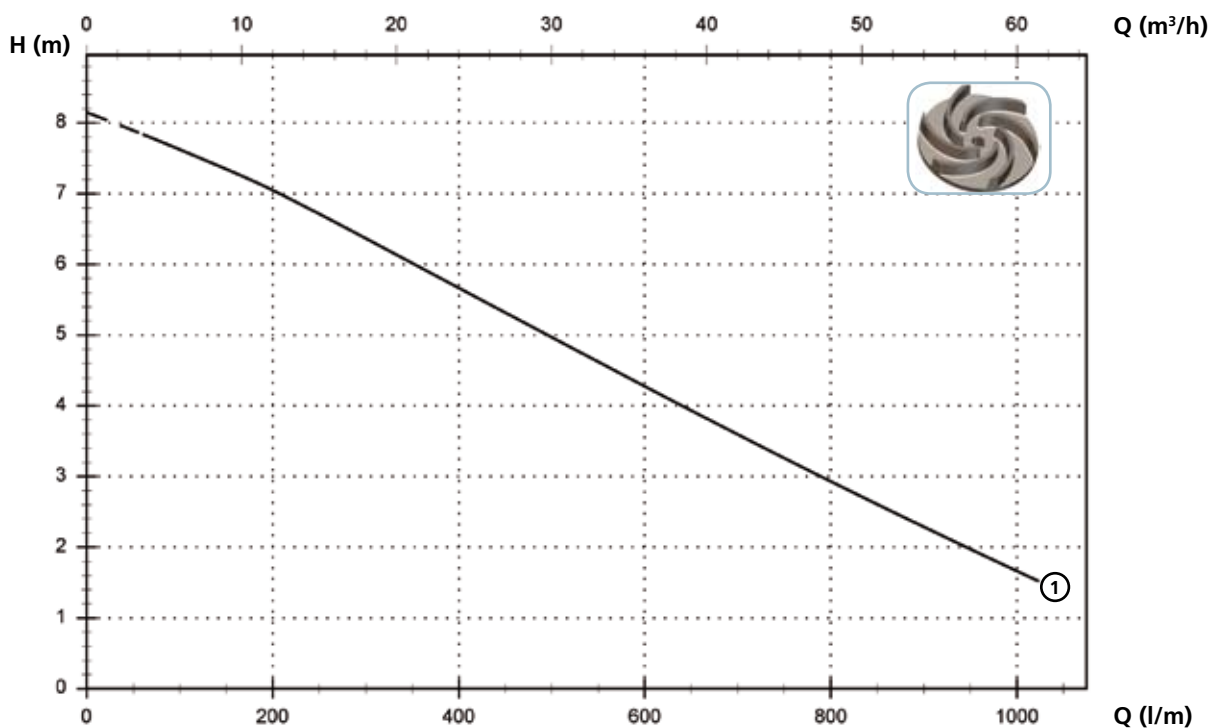

Technical data

	V	Phases	P1 (kW)	P2 (kW)	A	Rpm	Ø	Cable (*)	Free passage
① DGX 200/2/80 A0CM/50	230	1	-	1.5	9.3	2900	DN80 PN10	A	60 mm

	V	Phases	P1 (kW)	P2 (kW)	A	Rpm	Ø	Cable (*)	Free passage
① DGX 200/2/80 A0CT/50	400	3	-	1.5	3.5	2900	DN80 PN10	A	60 mm

(*) A = H07RN-F 4G1 - 10 m

Models with vertical GAS 2" threaded delivery port - 4 poles

Performances

	l/s	0	1	2	3	4	5	6	7	8
	l/min	0	60	120	180	240	300	360	420	480
	m ³ /h	0	3,6	7,2	10,8	14,4	18,0	21,6	25,2	28,8
① DGX 100/4/G50V A0CM(T)/50		5,0	4,7	4,4	4,1	3,8	3,5	3,1	2,5	1,6

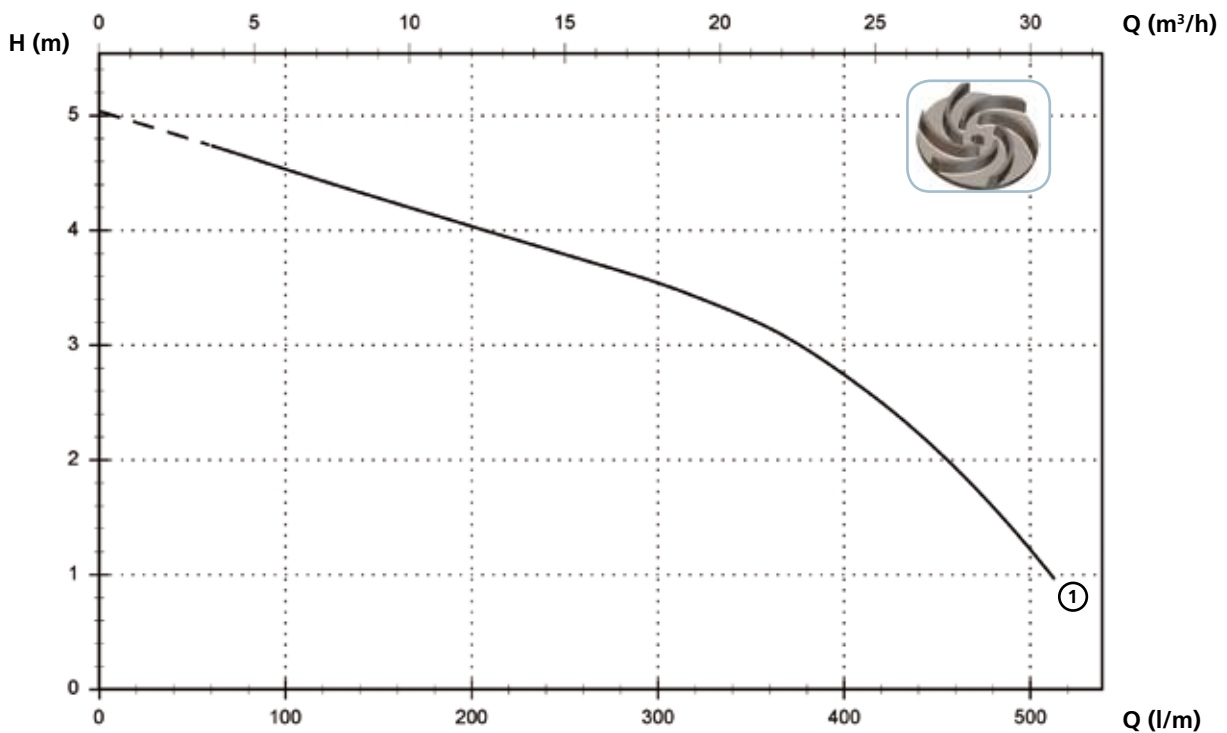

Technical data

	V	Phases	P1 (kW)	P2 (kW)	A	Rpm	Ø	Cable (*)	Free passage
① DGX 100/4/G50V A0CM/50	230	1	-	0.63	4.5	1450	G 2"	A	20 mm

	V	Phases	P1 (kW)	P2 (kW)	A	Rpm	Ø	Cable (*)	Free passage
① DGX 100/4/G50V A0CT/50	400	3	-	0.63	1.85	1450	G 2"	A	20 mm

(*) A = H07RN-F 4G1 - 10 m

DGX

Models with horizontal DN65 PN10-16 flanged delivery port - 4 poles

Performances

<i>l/s</i>	0	2	4	6	8	10	12
<i>l/min</i>	0	120	240	360	480	600	720
<i>m³/h</i>	0	7,2	14,4	21,6	28,8	36,0	43,2

① DGX 150/4/65 A0CM(T)/50	5,6	5,3	4,8	4,3	3,6	2,8	1,8
---------------------------	-----	-----	-----	-----	-----	-----	-----

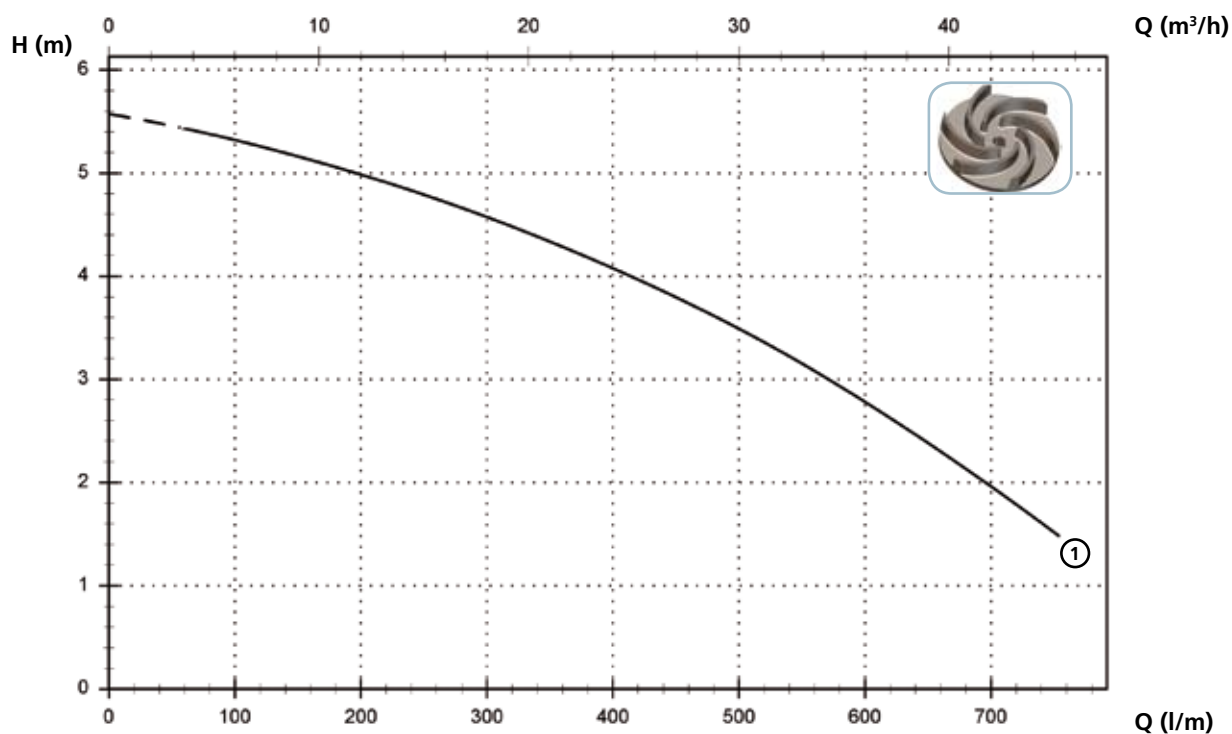

Technical data

	V	Phases	P1 (kW)	P2 (kW)	A	Rpm	Ø	Cable (*)	Free passage
① DGX 150/4/65 A0CM/50	230	1	-	0.9	6.3	1450	DN65 PN10-16	A	45 mm

	V	Phases	P1 (kW)	P2 (kW)	A	Rpm	Ø	Cable (*)	Free passage
① DGX 150/4/65 A0CT/50	400	3	-	0.9	2.2	1450	DN65 PN10-16	A	45 mm

(*) A = H07RN-F 4G1 - 10 m

Models with horizontal DN80 PN10 flanged delivery port - 4 poles

Performances

<i>l/s</i>	0	2	4	6	8	10	12	14	16	18
<i>l/min</i>	0	120	240	360	480	600	720	840	960	1080
<i>m³/h</i>	0	7,2	14,4	21,6	28,8	36,0	43,2	50,4	57,6	64,8

① DGX 150/4/80A A0CM(T)/50	5,1	4,8	4,5	4,0	3,5	3,1	2,6	2,1	1,6	1,1
----------------------------	-----	-----	-----	-----	-----	-----	-----	-----	-----	-----

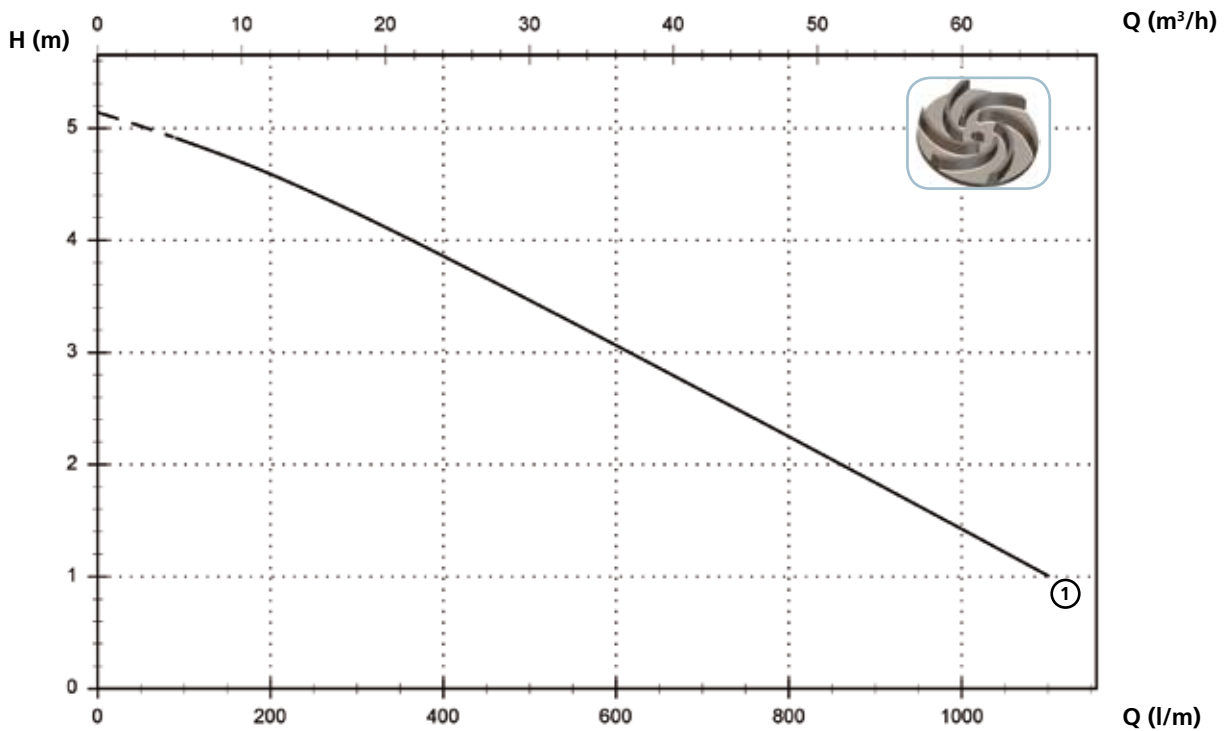

Technical data

	V	Phases	P1 (kW)	P2 (kW)	A	Rpm	Ø	Cable (*)	Free passage
① DGX 150/4/80A0CM/50	230	1	-	0.9	6.3	1450	DN80 PN10	A	60 mm

	V	Phases	P1 (kW)	P2 (kW)	A	Rpm	Ø	Cable (*)	Free passage
① DGX 150/4/80A0CT/50	400	3	-	0.9	2.23	1450	DN80 PN10	A	60 mm

(*) A = H07RN-F 4G1 - 10 m

DGX

Versions available

(Key to versions on page 15)

	Electrical variants												Cooling		Mechanical seals				
	N A E	T C	T C D	T C D T	T C D G T	T C G	T C S T	T C S G T	T S	T R	T R G	F T	C G F T	N	CC	2SIC	SICM	SICAL	2SICAL
DGX 50/2/G50V A0CM/50		●					●	●						●		●			
DGX 75/2/G50V A0CM/50		●					●	●						●		●			
DGX 100/2/G50V A0CM/50		●					●	●						●		●			
DGX 150/2/G50V A0CM/50		●					●	●						●		●			
DGX 200/2/G50V A0CM/50		●					●	●						●		●			
DGX 50/2/G50V A0CT/50	●													●		●			
DGX 75/2/G50V A0CT/50	●													●		●			
DGX 100/2/G50V A0CT/50	●													●		●			
DGX 150/2/G50V A0CT/50	●													●		●			
DGX 200/2/G50V A0CT/50	●													●		●			
DGX 150/2/65 A0CM/50		●					●	●						●		●			
DGX 200/2/65 A0CM/50		●					●	●						●		●			
DGX 150/2/65 A0CT/50	●													●		●			
DGX 200/2/65 A0CT/50	●													●		●			
DGX 200/2/80 A0CM/50		●					●	●						●		●			
DGX 200/2/80 A0CT/50	●													●		●			
DGX 100/4/G50V A0CM/50		●					●	●						●		●			
DGX 100/4/G50V A0CT/50	●													●		●			
DGX 150/4/65 A0CM/50		●					●	●						●		●			
DGX 150/4/65 A0CT/50	●													●		●			
DGX 150/4/80 A0CM/50		●					●	●						●		●			
DGX 150/4/80 A0CT/50	●													●		●			

Overall dimensions and weights

Models with vertical delivery port

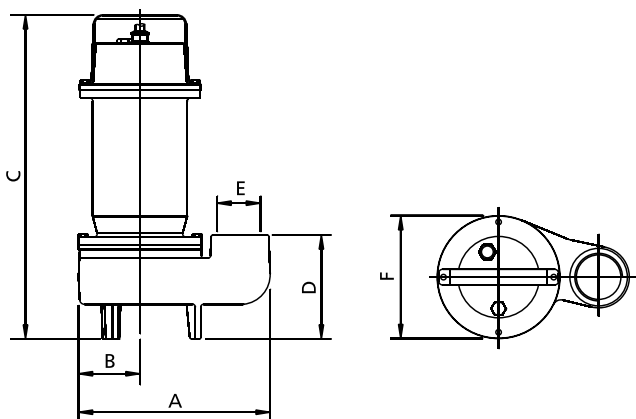

	A	B	C	D	E	F	kg
DGX 50/2/G50V A0CM(T)/50	225	75	360	120	G 2"	155	18
DGX 75/2/G50V A0CM(T)/50	225	75	360	120	G 2"	155	18
DGX 100/2/G50V A0CM (T)/50	245	80	410	130	G 2"	155	22
DGX 150/2/G50V A0CM (T)/50	245	80	410	130	G 2"	155	23
DGX 200/2/G50V A0CM (T)/50	245	80	410	130	G 2"	155	22
DGX 100/4/G50V A0CM (T)/50	245	80	410	130	G 2"	155	22

Measurements in mm

Overall dimensions and weights

Models with horizontal delivery port

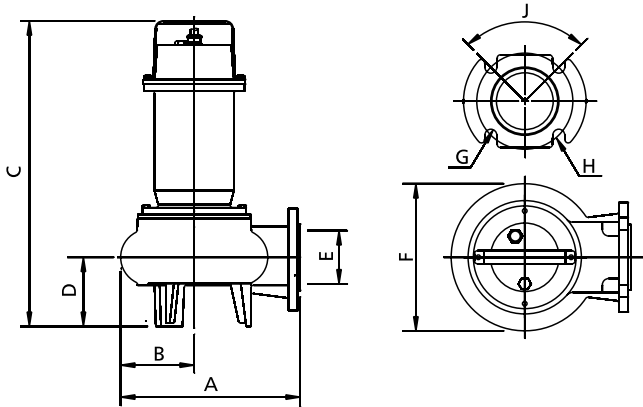

	A	B	C	D	E	F	G	H	J	kg
DGX 150/2/65 A0CM(T)/50	270	110	460	105	65	220	18	145	90°	28
DGX 200/2/65 A0CM(T)/50	270	110	460	105	65	220	18	145	90°	29
DGX 200/2/80 A0CM(T)/50	270	110	460	105	80	220	18	160	90°	33.5
DGX 150/4/65 A0CM(T)/50	270	110	460	105	65	220	18	145	90°	29
DGX 150/4/80 A0CM(T)/50	295	120	470	115	80	220	18	160	90°	33.5

Measurements in mm

Packaging dimension

	A	B	C
DGX 50/2/G50V A0CM(T)/50	385	225	245
DGX 75/2/G50V A0CM(T)/50	385	225	245
DGX 100/2/G50V A0CM(T)/50	475	285	235
DGX 150/2/G50V A0CM(T)/50	475	285	235
DGX 200/2/G50V A0CM(T)/50	475	285	235
DGX 100/4/G50V A0CM(T)/50	580	310	310
DGX 150/2/65 A0CM(T)/50	580	310	310
DGX 200/2/65 A0CM(T)/50	580	310	310
DGX 200/2/80 A0CM(T)/50	580	310	310
DGX 150/4/65 A0CM(T)/50	580	310	310
DGX 150/4/80 A0CM(T)/50	580	310	310

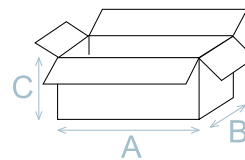

Dimension in mm

Installations available

